



SI04000

DE: FAHRRADGARAGE

EN: BICYCLE GARAGE

PL: GARAŻ ROWEROWY

SK: GARÁŽ NA BICYKLE

CZ: GARÁŽ NA KOLA

NL: FIETSGARAGE

FR: GARAGE À VÉLOS

IT: GARAGE PER BICICLETTE

HU: KERÉKPÁRGARÁZS

RO: GARAJ PENTRU BICICLETE



MONTAGEANLEITUNG

Bitte lesen Sie alle Anweisungen in der Bedienungsanleitung sorgfältig durch, bevor Sie das Gerät in Betrieb nehmen. Die 50NRTH GmbH behält sich das Recht vor, die Bedienungsanleitung eindeutig auszulegen. Das Aussehen des Produkts richtet sich nach dem Produkt, das Sie erhalten haben. Bitte haben Sie Verständnis dafür, dass wir Sie nicht erneut informieren, wenn es technische Updates für unser Produkt gibt.

ASSEMBLY INSTRUCTIONS

Please read all instructions in the manual carefully before operating the product. 50NRTH GmbH reserves the right to interpret the manual. The appearance of the product is based on the product you have received. Please understand that we may not provide separate notifications regarding technical updates to the product.

INSTRUKCJA MONTAŻU

Przed uruchomieniem produktu należy dokładnie przeczytać wszystkie instrukcje zawarte w podręczniku. Firma 50NRTH GmbH zastrzega sobie prawo do ostatecznej interpretacji instrukcji. Wygląd produktu zależy od otrzymanego modelu. Prosimy o zrozumienie, że nie będziemy osobno informować o aktualizacjach technicznych produktu.

NÁVOD NA MONTÁŽ

Pred uvedením výrobku do prevádzky si pozorne prečítajte všetky pokyny v návode na obsluhu. Spoločnosť 50NRTH GmbH si vyhradzuje právo na konečný výklad návodu. Vzhľad produktu závisí od výrobku, ktorý ste dostali. Prosíme o pochopenie, že o technických aktualizáciách produktu nemusíme poskytovať samostatné oznámenia.

NÁVOD K MONTÁŽI

Před uvedením výrobku do provozu si pečlivě přečtete všechny pokyny v návodu k obsluze. Společnost 50NRTH GmbH si vyhradzuje právo na konečný výklad návodu. Vzhled produktu odpovídá výrobku, který jste obdrželi. Berte prosím na vědomí, že o technických aktualizacích výrobku nemusíme poskytovat samostatná oznámení.

MONTAGEHANDLEIDING

Lees alle instructies in de handleiding zorgvuldig door voordat u het product in gebruik neemt. 50NRTH GmbH behoudt zich het recht voor om de handleiding te interpreteren. Het uiterlijk van het product is afhankelijk van het ontvangen product. Houd er rekening mee dat wij geen afzonderlijke kennisgeving verstrekken over technische updates van het product.

NOTICE DE MONTAGE

Veuillez lire attentivement toutes les instructions du manuel avant de mettre le produit en service. 50NRTH GmbH se réserve le droit d'interpréter le manuel. L'apparence du produit dépend du produit que vous avez reçu. Veuillez comprendre que nous ne fournirons pas nécessairement de notification distincte concernant les mises à jour techniques du produit.

ISTRUZIONI DI MONTAGGIO

Leggere attentamente tutte le istruzioni contenute nel manuale prima di utilizzare il prodotto. 50NRTH GmbH si riserva il diritto di interpretare il manuale. L'aspetto del prodotto dipende dal prodotto ricevuto. Si prega di comprendere che potremmo non fornire notifiche separate riguardo agli aggiornamenti tecnici del prodotto.

SZERELÉSI ÚTMUTATÓ

A termék üzembe helyezése előtt figyelmesen olvassa el a használati útmutató összes utasítását. A 50NRTH GmbH fenntartja a jogot az útmutató végső értelmezésére. A termék megjelenése a kapott terméktől függ. Kérjük megértésüket, hogy a termék műszaki frissítéseiről nem feltétlenül küldünk külön értesítést.

INSTRUCȚIUNI DE ASAMBLARE

Vă rugăm să citiți cu atenție toate instrucțiunile din manual înainte de punerea în funcțiune a produsului. 50NRTH GmbH își rezervă dreptul de a interpreta manualul. Aspectul produsului depinde de produsul primit. Vă rugăm să înțelegeți că este posibil să nu transmitem notificări separate privind actualizările tehnice ale produsului.

DE – Sicherheitshinweise

- Lesen Sie vor der Montage die Aufbauanleitung vollständig. Montieren Sie die Fahrradgarage mit mindestens zwei Personen nur bei trockenem, windstillem Wetter; tragen Sie Schutzhandschuhe, Schutzbrille und lange Kleidung. Blechteile können scharfe Kanten haben.
- Stellen Sie die Garage auf einem ebenen, tragfähigen und gut entwässerten Fundament auf und verankern Sie sie sicher gegen Wind. Beachten Sie die örtlichen Bauvorschriften.
- Benutzen Sie die Garage erst nach vollständiger Montage und festem Anziehen aller Verbindungen. Steigen Sie nicht auf Wände oder Dach und bringen Sie keine zusätzlichen Lasten an.
- Bewegen Sie die Schiebetüren langsam und kontrolliert. Halten Sie Hände von Schließkanten und Führungsschienen fern. Halten Sie die Schienen sauber und schmieren Sie diese bei Bedarf sparsam.
- Stellen Sie Fahrräder standsicher ab und halten Sie Zugang und Türen frei.
- Prüfen Sie regelmäßig sowie nach Unwettern Verankerung, Standsicherheit, Schrauben, Dach, Korrosion, scharfe Kanten und Beschädigungen. Entfernen Sie Schnee und Laub mit geeignetem Werkzeug vom Boden aus. Bei Schäden oder losen Teilen nicht benutzen.
- Nur zur Aufbewahrung verwenden. Verpackungen und ausgediente Bauteile nach Material trennen und gemäß den örtlichen Vorschriften entsorgen; Metall dem Recycling zuführen.

EN – Safety Instructions

- Read the assembly instructions completely before installation. Assemble the bicycle garage with at least two people and only in dry, calm weather; wear protective gloves, safety glasses and long clothing. Sheet-metal parts may have sharp edges.
- Install the garage on a level, load-bearing and well-drained foundation and securely anchor it against wind. Observe local building regulations.
- Do not use the garage until assembly is complete and all connections are firmly tightened. Do not climb on the walls or roof or attach additional loads.
- Move the sliding doors slowly and carefully. Keep hands away from closing edges and guide rails. Keep the rails clean and lubricate them sparingly when necessary.
- Park bicycles securely and keep the entrance and doors clear.
- Regularly and after severe weather check the anchoring, stability, screws, roof, corrosion, sharp edges and damage. Remove snow and leaves from ground level using suitable tools. Do not use the garage if parts are damaged or loose.
- Use for storage only. Separate packaging and discarded components by material and dispose of them according to local regulations; recycle metal.

PL – Instrukcje bezpieczeństwa

- Przed montażem przeczytać całą instrukcję. Garaż rowerowy montować w co najmniej dwie osoby, wyłącznie przy suchej i bezwietrznej pogodzie; używać rękawic ochronnych, okularów i odzieży z długimi rękawami. Elementy blaszane mogą mieć ostre krawędzie.
- Ustawić garaż na równym, nośnym i dobrze odwodnianym fundamencie oraz bezpiecznie zakotwić go przed działaniem wiatru. Przestrzegać lokalnych przepisów budowlanych.
- Użytkować dopiero po pełnym montażu i dokręceniu wszystkich połączeń. Nie wchodzić na ściany ani dach i nie mocować dodatkowych obciążeń.
- Drzwi przesuwne poruszać powoli i ostrożnie. Trzymać ręce z dala od krawędzi zamykających i prowadnic. Prowadnice utrzymywać w czystości i w razie potrzeby oszczędnie smarować.
- Rowery ustawiać stabilnie, a wejście i drzwi pozostawiać wolne.
- Regularnie i po burzach kontrolować zakotwienie, stabilność, śruby, dach, korozję, ostre krawędzie i uszkodzenia. Śnieg i liście usuwać odpowiednim narzędziem z poziomu podłoża. Nie używać w przypadku uszkodzonych lub luźnych części.
- Używać wyłącznie do przechowywania. Opakowania i zużyte części segregować według materiału i usuwać zgodnie z lokalnymi przepisami; metal oddać do recyklingu.

SK – Bezpečnostné pokyny

- Pred montážou si prečítajte celý návod. Garaž na bicykle montujte najmenej vo dvojici, iba za suchého a bezveterného počasia; používajte ochranné rukavice, okuliare a odev s dlhými rukávami. Plechové diely môžu mať ostré hrany.
- Garaž postavte na rovný, nosný a dobre odvodnený základ a bezpečne ju ukotvite proti vetru. Dodržiavajte miestne stavebné predpisy.
- Používajte ju až po úplnej montáži a pevnom dotiahnutí všetkých spojov. Nelezte na steny ani strechu a nepripevňujte dodatočné zaťaženie.
- Posuvné dvere otvárajte a zatvárajte pomaly a kontrolované. Ruky držte mimo zatváracích hrán a vodiacich koľajníc. Koľajnice udržiavajte čisté a podľa potreby ich mierne namažte.
- Bicykle odstavte stabilne a udržiavajte vstup aj dvere voľné.
- Pravidelne a po nepriaznivom počasí kontrolujte ukotvenie, stabilitu, skrutky, strechu, koróziu, ostré hrany a poškodenia. Sneh a lístie odstraňujte vhodným náradím zo zeme. Pri poškodených alebo uvoľnených dieloch garaž nepoužívajte.
- Používajte iba na skladovanie. Obaly a vyradené diely roztriedte podľa materiálu a zlikvidujte podľa miestnych predpisov; kov odovzdajte na recykláciu.

CZ – Bezpečnostní pokyny

- Před montáží si přečtěte celý návod. Garaž na jízdní kola montujte nejméně ve dvou osobách, pouze za suchého a bezvětrného počasí; použijte ochranné rukavice, brýle a oděv s dlouhými rukávy. Plechové díly mohou mít ostré hrany.
- Garaž postavte na rovný, nosný a dobře odvodněný základ a bezpečně ji ukotvěte proti větru. Dodržujte místní stavební předpisy.
- Používejte ji až po úplné montáži a pevném dotažení

všech spojů. Nelezte na stěny ani střechu a nepřipevňujte dodatečná zatížení. • Posuvné dveře otevřete a zavírejte pomalu a kontrolovaně. Ruce držte mimo zavírací hrany a vodící kolejnice. Kolejnice udržujte čisté a podle potřeby je mírně promažte. • Jízdní kola odstavte stabilně a udržujte vstup i dveře volné. • Pravidelně a po nepříznivém počasí kontrolujte ukotvení, stabilitu, šrouby, střechu, korozi, ostré hrany a poškození. Sníh a listí odstraňujte vhodným náradím ze země. Při poškozených nebo uvolněných dílech garáž nepoužívejte. • Používejte pouze ke skladování. Obaly a vyřazené díly rozřídte podle materiálu a zlikvidujte podle místních předpisů; kov odevzdejte k recyklaci.

NL – Veiligheidsinstructies

• Lees vóór de montage de volledige handleiding. Monteer de fietsenberging met minstens twee personen en uitsluitend bij droog en windstil weer; draag veiligheidshandschoenen, een veiligheidsbril en kleding met lange mouwen. Plaatmetalen onderdelen kunnen scherpe randen hebben. • Plaats de berging op een vlakke, draagkrachtige en goed gedraineerde fundering en veranker deze stevig tegen wind. Neem de plaatselijke bouwvoorschriften in acht. • Gebruik de berging pas nadat deze volledig is gemonteerd en alle verbindingen stevig zijn vastgedraaid. Klim niet op de wanden of het dak en bevestig geen extra lasten. • Beweeg de schuifdeuren langzaam en gecontroleerd. Houd uw handen uit de buurt van sluitranden en geleiderails. Houd de rails schoon en smeer deze indien nodig spaarzaam. • Zet fietsen stabiel neer en houd de ingang en deuren vrij. • Controleer regelmatig en na zwaar weer de verankering, stabiliteit, schroeven, het dak, corrosie, scherpe randen en beschadigingen. Verwijder sneeuw en bladeren vanaf de grond met geschikt gereedschap. Gebruik de berging niet bij beschadigde of losse onderdelen. • Uitsluitend voor opslag gebruiken. Sorteert verpakkingen en afgedankte onderdelen naar materiaal en voer ze af volgens de plaatselijke voorschriften; recycle metaal.

FR – Consignes de sécurité

• Lire intégralement la notice avant le montage. Monter le garage à vélos à au moins deux personnes, uniquement par temps sec et sans vent; porter des gants, des lunettes de protection et des vêtements à manches longues. Les pièces en tôle peuvent présenter des bords tranchants. • Installer le garage sur une fondation plane, porteuse et correctement drainée, puis l'ancrer solidement contre le vent. Respecter les réglementations locales de construction. • Ne l'utiliser qu'après le montage complet et le serrage de toutes les fixations. Ne pas monter sur les parois ou le toit et ne pas fixer de charges supplémentaires. • Déplacer les portes coulissantes lentement et de manière contrôlée. Tenir les mains éloignées des bords de fermeture et des rails de guidage. Maintenir les rails propres et les lubrifier modérément si nécessaire. • Ranger les vélos de manière stable et maintenir l'entrée et les portes dégagées. • Contrôler régulièrement et après les intempéries les ancrages, la stabilité, les vis, le toit, la corrosion, les bords tranchants et les détériorations. Retirer la neige et les feuilles depuis le sol avec un outil adapté. Ne pas utiliser le garage si des pièces sont endommagées ou desserrées. • Utiliser uniquement pour le stockage. Trier les emballages et les composants usagés par matériau et les éliminer conformément aux règles locales; recycler le métal.

IT – Istruzioni di sicurezza

• Leggere integralmente le istruzioni prima del montaggio. Montare il garage per biciclette in almeno due persone, esclusivamente con tempo asciutto e senza vento; indossare guanti, occhiali protettivi e indumenti a maniche lunghe. Le parti in lamiera possono presentare bordi taglienti. • Installare il garage su una fondazione piana, portante e ben drenata e ancorarlo saldamente contro il vento. Rispettare le norme edilizie locali. • Utilizzarlo solo dopo il montaggio completo e il serraggio di tutti i collegamenti. Non salire sulle pareti o sul tetto e non applicare carichi aggiuntivi. • Muovere le porte scorrevoli lentamente e in modo controllato. Tenere le mani lontane dai bordi di chiusura e dalle guide. Mantenere pulite le guide e lubrificarle con moderazione quando necessario. • Sistemare le biciclette in modo stabile e mantenere liberi l'ingresso e le porte. • Controllare regolarmente e dopo le intemperie gli ancoraggi, la stabilità, le viti, il tetto, la corrosione, i bordi taglienti e i danni. Rimuovere neve e foglie da terra con utensili adeguati. Non utilizzare il garage in presenza di parti danneggiate o allentate. • Utilizzare esclusivamente per il deposito. Separare gli imballaggi e i componenti dismessi per materiale e smaltirli secondo le norme locali; riciclare il metallo.

HU – Biztonsági utasítások

• Összeszerelés előtt olvassa el a teljes útmutatót. A kerékpárgarázst legalább két személy szerelje össze, kizárólag száraz, szélcsendes időben; viseljen védőkesztyűt, védőszemüveget és hosszú ujjú ruházatot. A lemezalkatrészek szélei élesek lehetnek. • A garázst sík, teherbíró és megfelelő vízelvezetésű alapra állítsa, és biztonságosan rögzítse a széllel szemben. Tartsa be a helyi építési előírásokat. • Csak teljes összeszerelés és valamennyi kötés meghúzása után használja. Ne másszon a falakra vagy a tetőre, és ne rögzítsen további terheket. • A tolóajtókat lassan és ellenőrzötten mozgassa. Tartsa távol a kezét a záródó élektől és a vezetősínektől. A síneket tartsa tisztán, és szükség esetén takarékosan kenje meg. • A kerékpárokat stabilan állítsa le, a bejáratot és az ajtókat tartsa szabadon. • Rendszeresen és viharok után ellenőrizze a

rögzítést, stabilitást, csavarokat, tetőt, korróziót, éles széleket és sérüléseket. A havat és leveleket megfelelő eszközzel, a talajról távolítsa el. Sérült vagy laza alkatrészek esetén ne használja. • Kizárólag tárolásra használja. A csomagolást és a leselejtezett alkatrészeket anyaguk szerint válogassa szét, és a helyi előírások szerint ártalmatlanítsa; a fémet hasznosítsa újra.

RO – Instrucțiuni de siguranță

- Citiți integral instrucțiunile înainte de montaj. Montați garajul pentru biciclete cu cel puțin două persoane, numai pe vreme uscată și fără vânt; purtați mănuși, ochelari de protecție și îmbrăcăminte cu mâneci lungi. Componentele din tablă pot avea margini ascuțite.
- Amplasați garajul pe o fundație plană, portantă și bine drenată și ancorați-l sigur împotriva vântului. Respectați reglementările locale privind construcțiile.
- Utilizați-l numai după montarea completă și strângerea tuturor îmbinărilor. Nu vă urcați pe pereți sau pe acoperiș și nu fixați sarcini suplimentare.
- Mișcați ușile glisante lent și controlat. Țineți mâinile departe de marginile de închidere și șinele de ghidare. Mențineți șinele curate și lubrificați-le cu moderație atunci când este necesar.
- Parcați bicicletele stabil și mențineți intrarea și ușile libere.
- Verificați periodic și după furtuni ancorarea, stabilitatea, șuruburile, acoperișul, coroziunea, marginile ascuțite și deteriorările. Îndepărtați zăpada și frunzele de la nivelul solului cu unelte adecvate. Nu utilizați garajul dacă există componente deteriorate sau slăbite.
- Utilizați exclusiv pentru depozitare. Separați ambalajele și componentele scoase din uz în funcție de material și eliminați-le conform reglementărilor locale; reciclați metalul.

Aufstellmaße der Westmann Fahrradgarage nach Montage

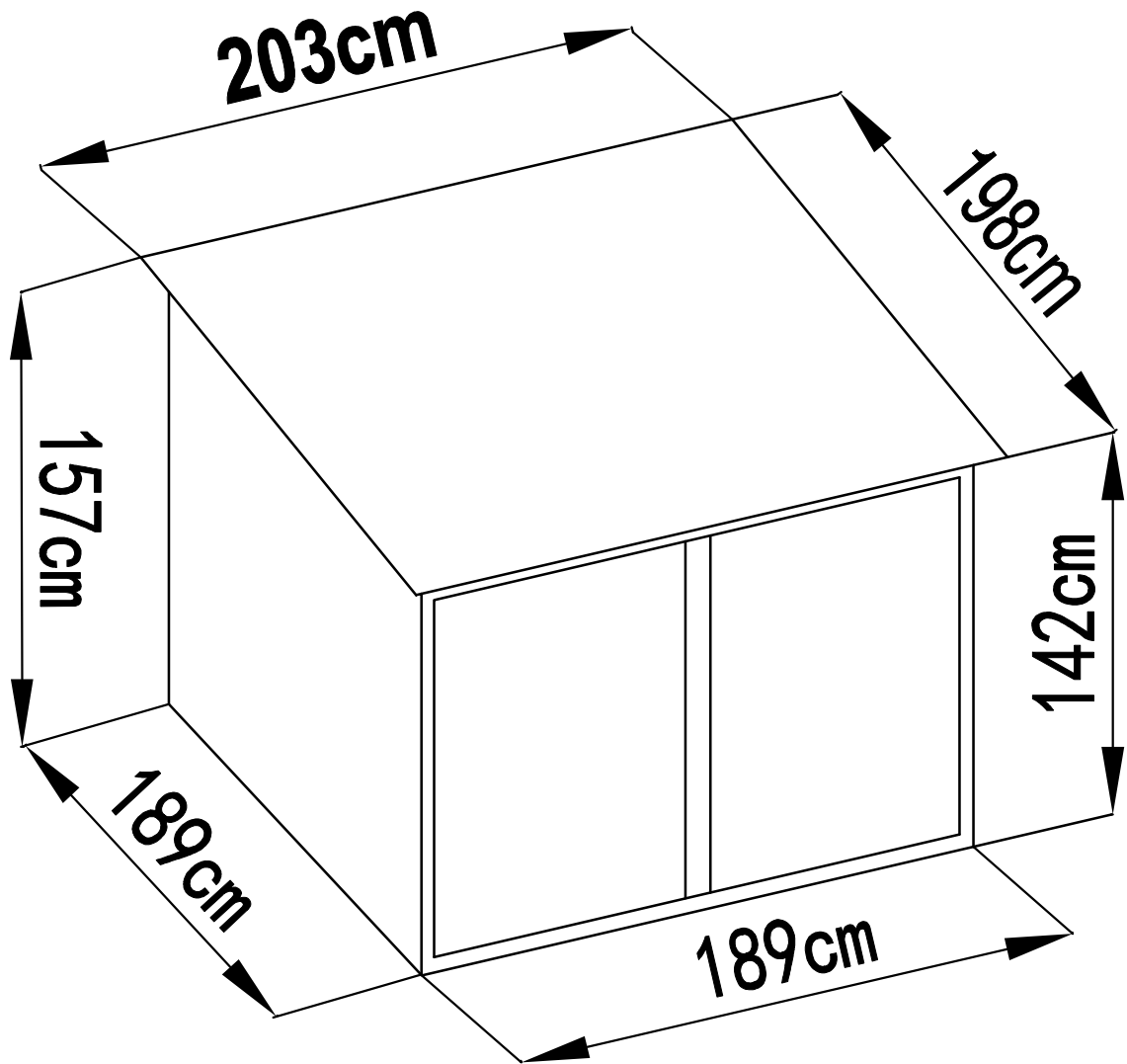



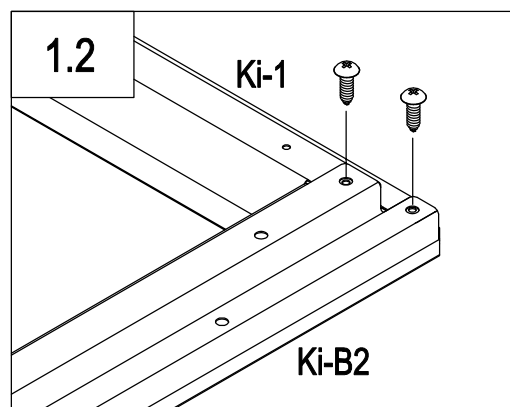
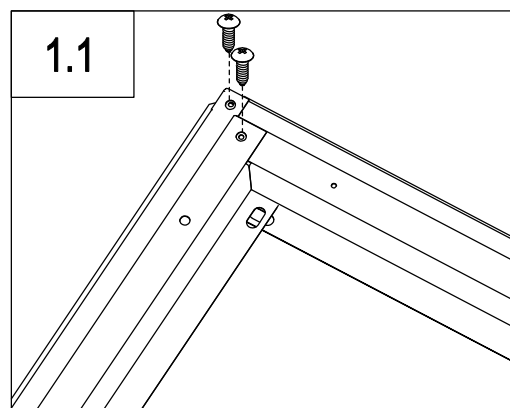
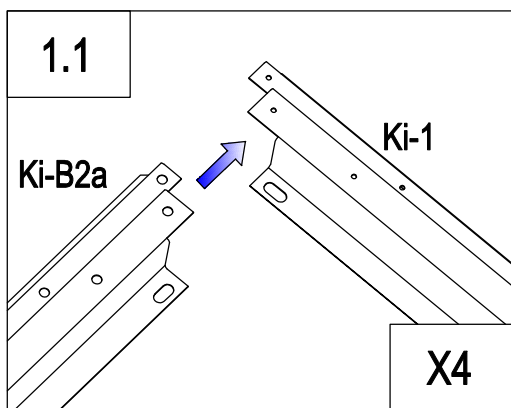
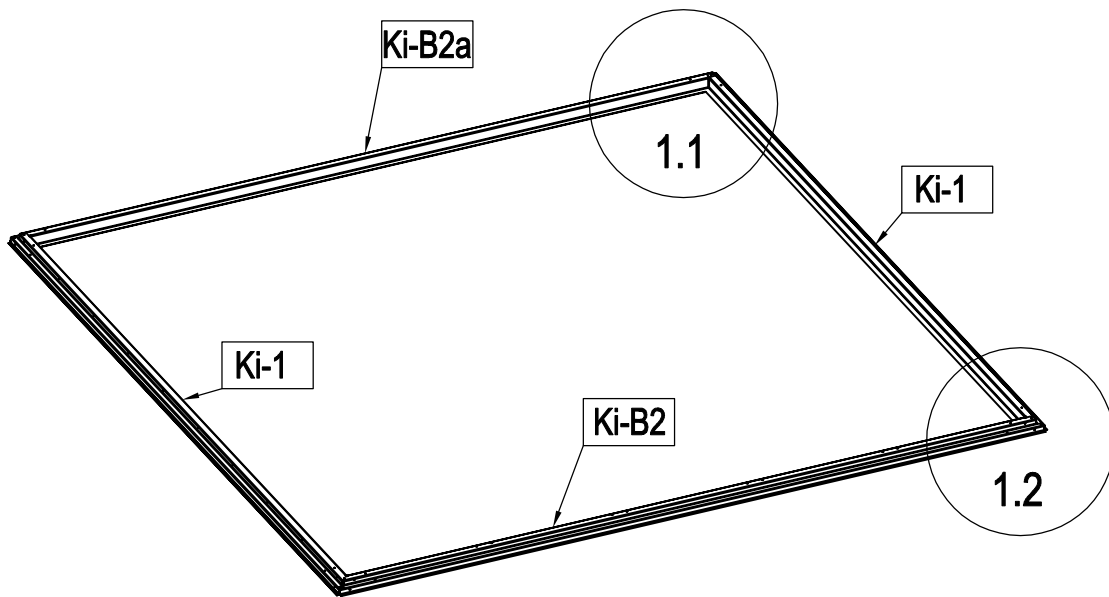

Teileliste

IMAGE	NO.	L.	QTY	IMAGE	NO.	L.	QTY		
	Ki-1	1889.5	2		Ki-B23	902.5	2		
	Ki-B2	1889.5	1		Ki-B23a	902.5	2		
	Ki-B2a	1889.5	1		Ki-24	1355	1		
	Ki-3	1415	1		Ki-24a	1355	1		
	Ki-3a	1415	1		Ki-25	1355	1		
	Ki-4	1553	2		Ki-26	1355	1		
	Ki-B5	1895.5	1		Ki-27	880	1		
	Ki-B6	1895.5	1	Ki-28	300	1			
	Ki-7	1865	1		Ki-B29	1352	1		
	Ki-7a	1865	1		Ki-B29a	1352	1		
	Ki-8	1507	3		Ki-B30	1352	1		
	Ki-9	1507	1		Ki-B31	1352	1		
	Ki-9a	1507	1		Ki-32	768.5	2		
	Ki-10	1465	1		Ki-32a	768.5	2		
	Ki-10a	1465	1		Ki-33	1364	2		
	Ki-11	1420	1		Ki-34	1340	2		
	Ki-11a	1420	1		Ki-36	635	2		
	Ki-12	1042.5	1	Ki-37	540	2			
	Ki-12a	1042.5	1		Ki-38	655	8		
	Ki-13	1042.5	2		Ki-39	475	4		
	Ki-13a	1042.5	2		Ki-40	385	4		
	Ki-14	1042.5	1		Ki-41	235	2		
	Ki-14a	1042.5	1		Ki-42	335	1		
	Ki-B15	1897	1	Ki-B43	1872	1			
		Ki-16	960.5	2		Ki-47		2	
		Ki-17	1044.5	2			Ki-49		4
		Ki-B18	1218	2			Ki-B44		212
		Ki-B19	818	1			Ki-B45		80
Ki-B19a		818	1		Ki-B46		16		
	Ki-B20	1206	2			Ki-B50		120	
	Ki-B21	1023.5	4			Ki-51		32	
	Ki-48		1			BCP3		4	
		Ki-35		1					
Ki-35a			1						

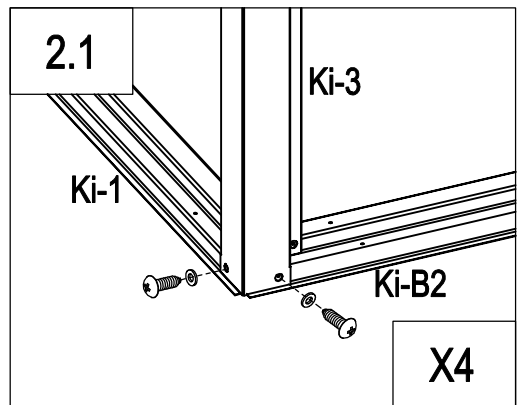
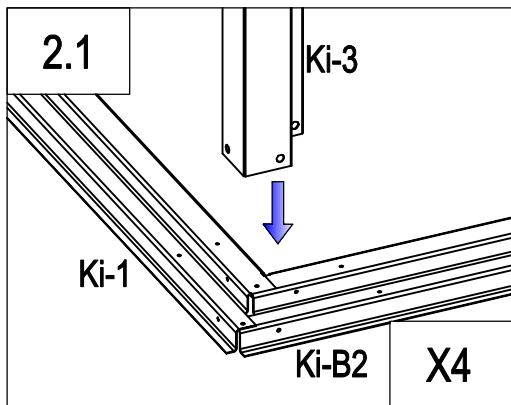
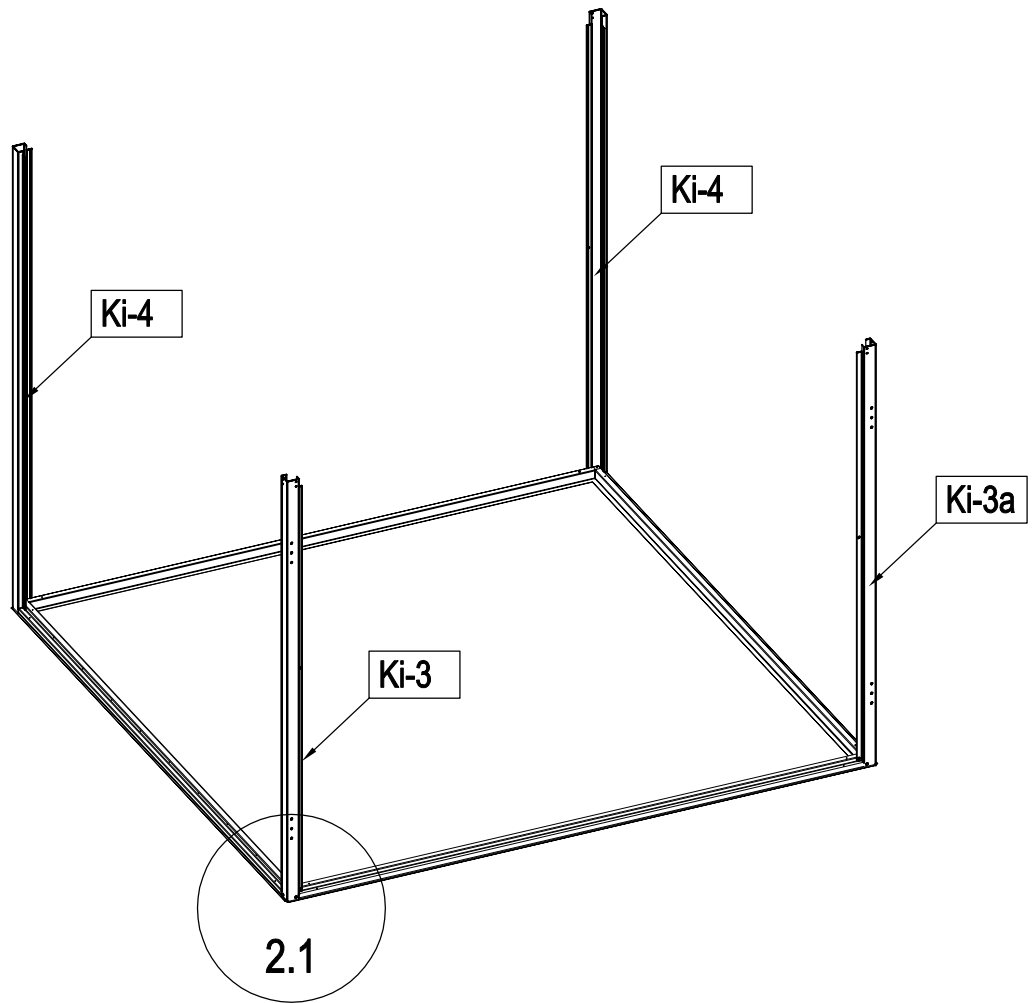

	Ki-1	2
	Ki-B2	1
	Ki-B2a	1
	Ki-B44	8



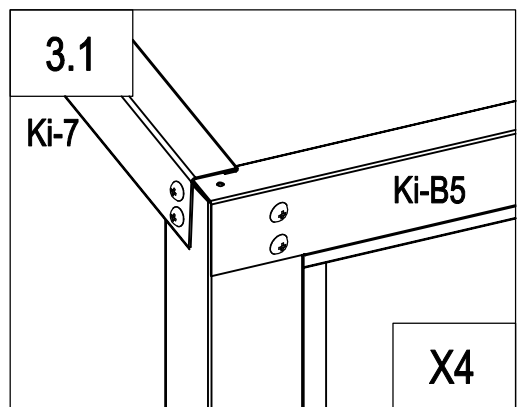
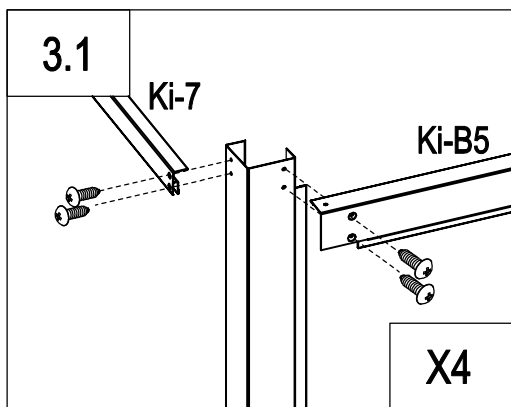
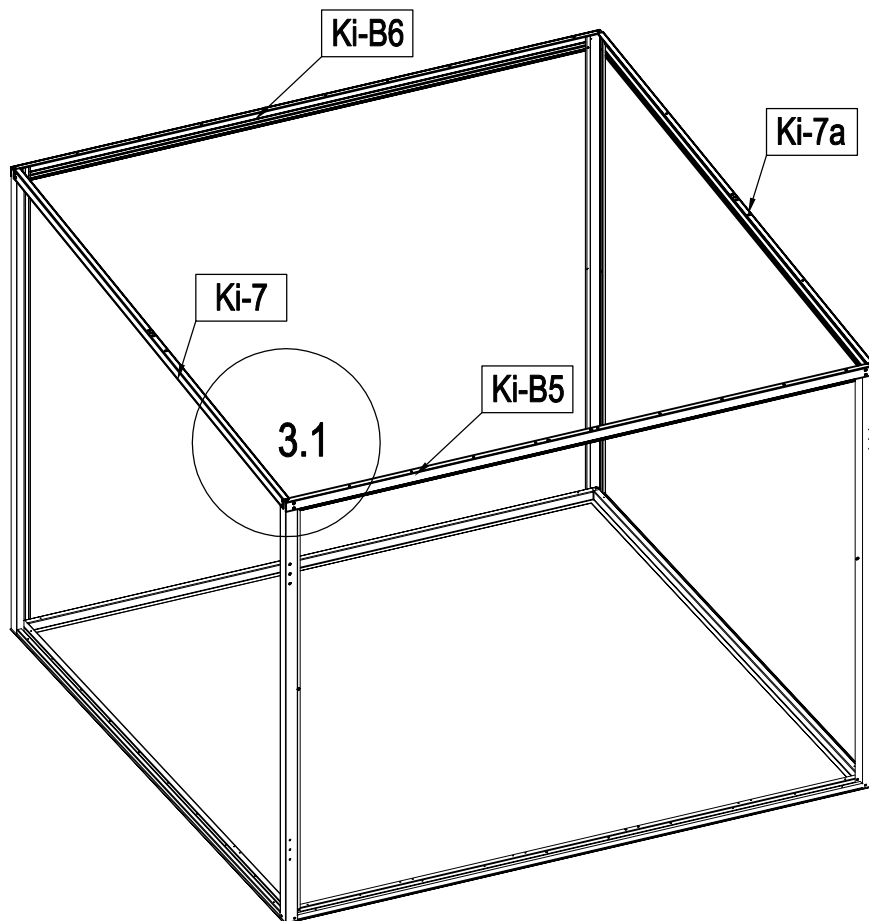

	Ki-3	1
	Ki-3a	1
	Ki-4	2
	Ki-B44	8



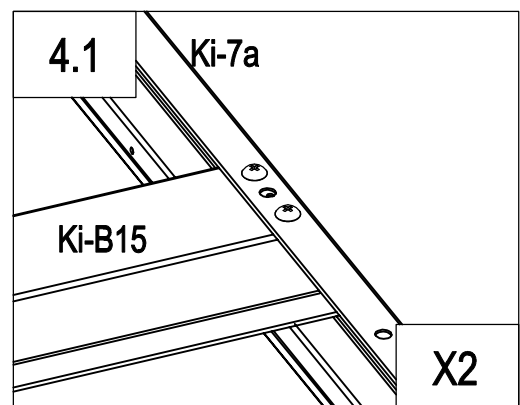
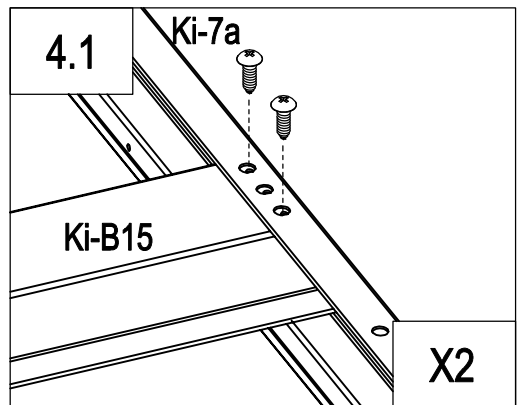
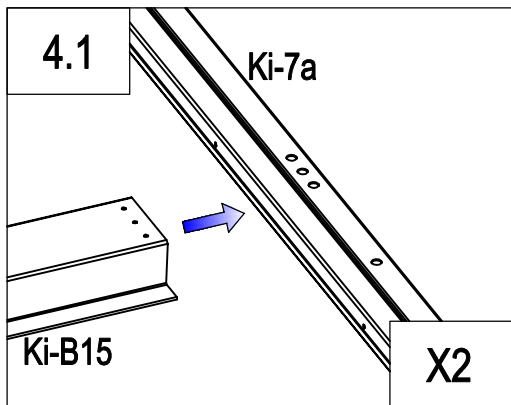
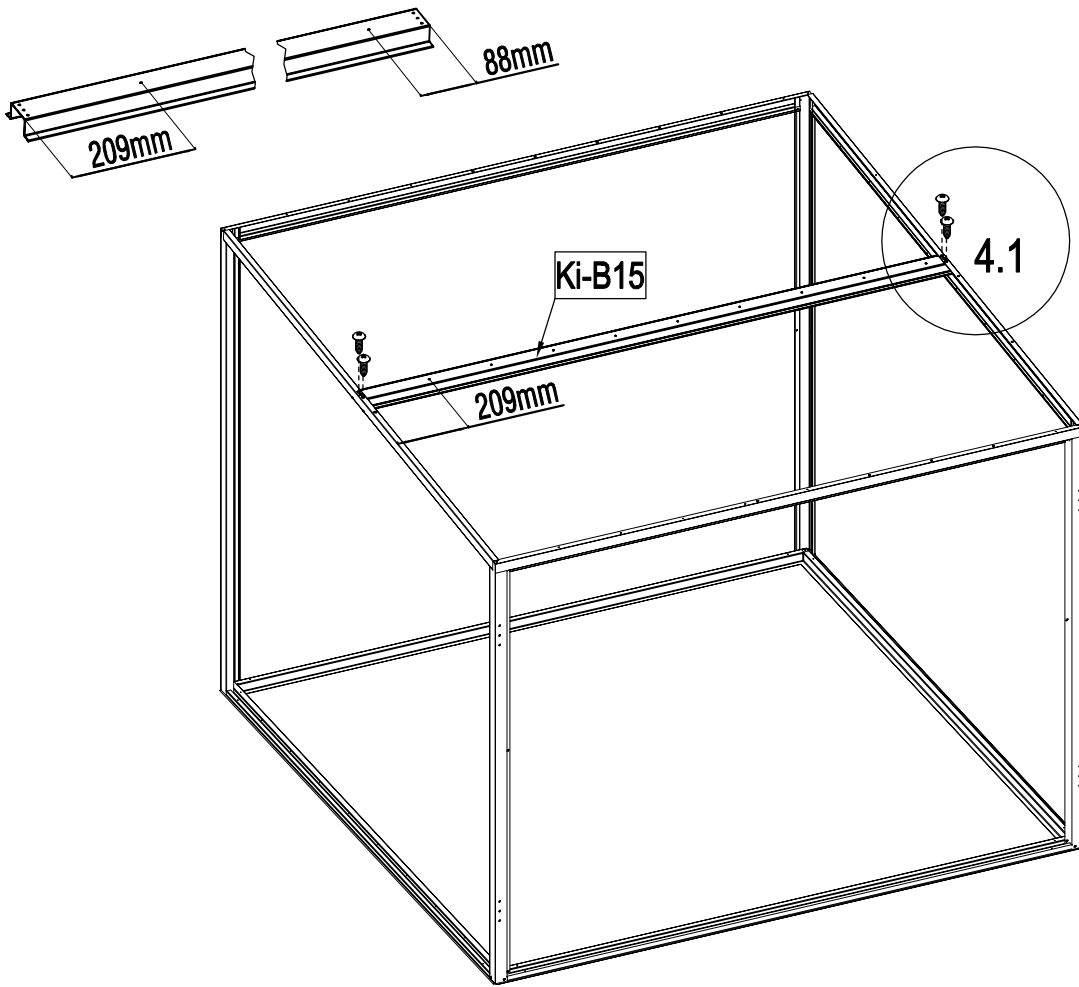

	Ki-7a	1
	Ki-7	1
	Ki-B6	1
	Ki-B5	1
	Ki-B44	16

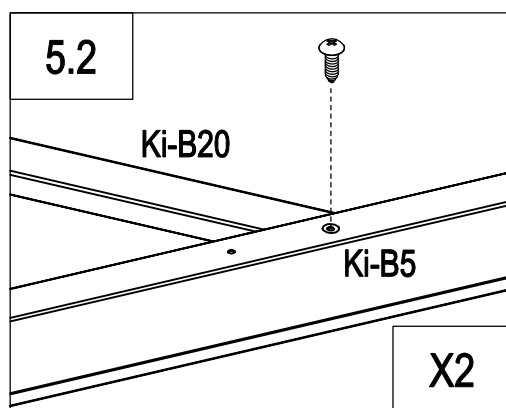
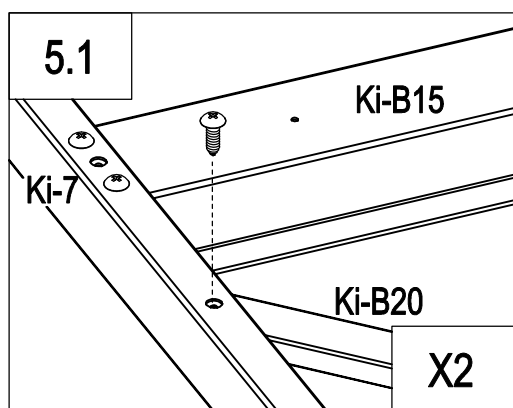
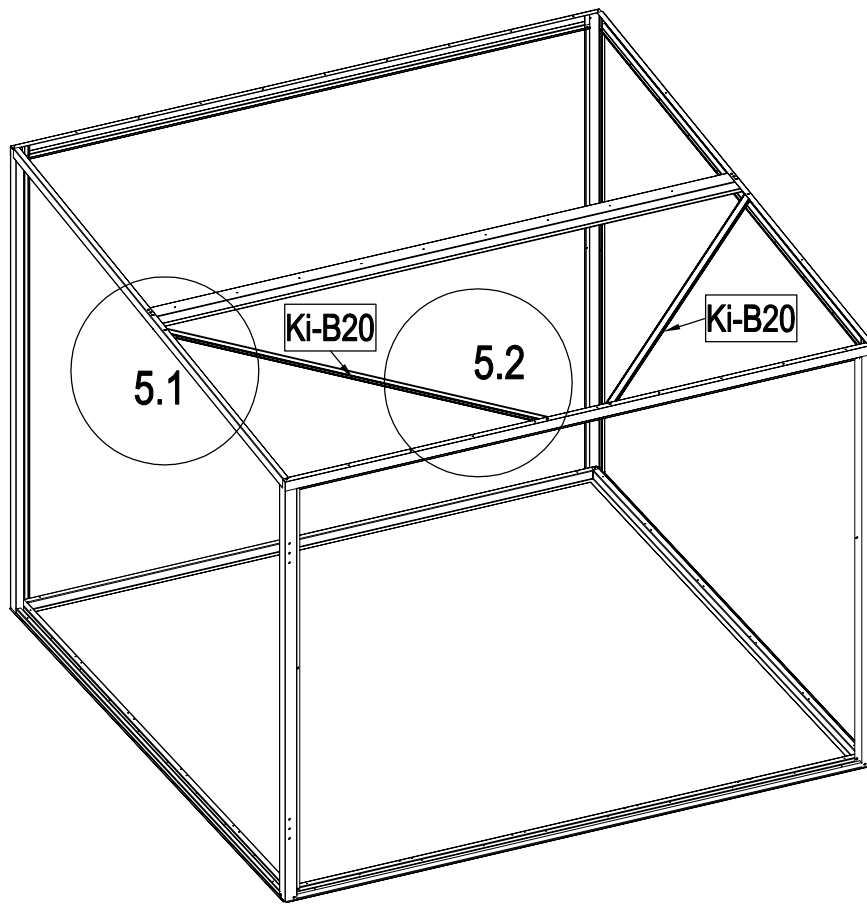

	Ki-B15	1
	Ki-B44	4



	Ki-B20	2
	Ki-B44	4

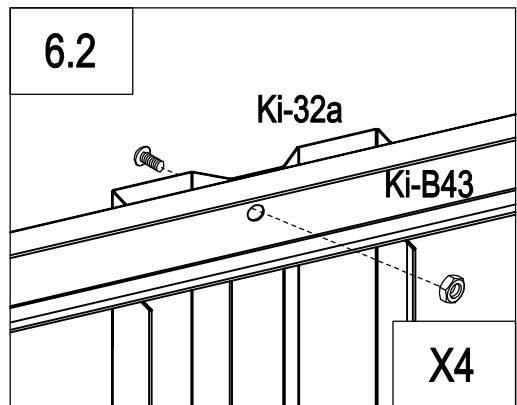
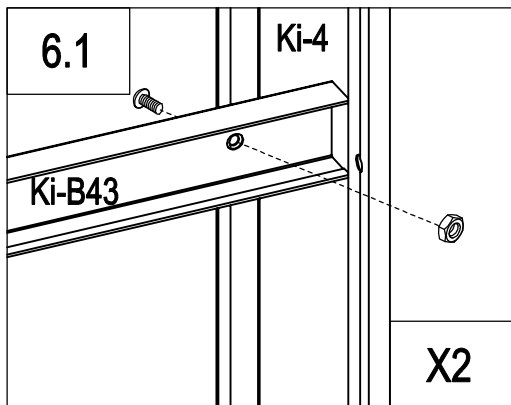
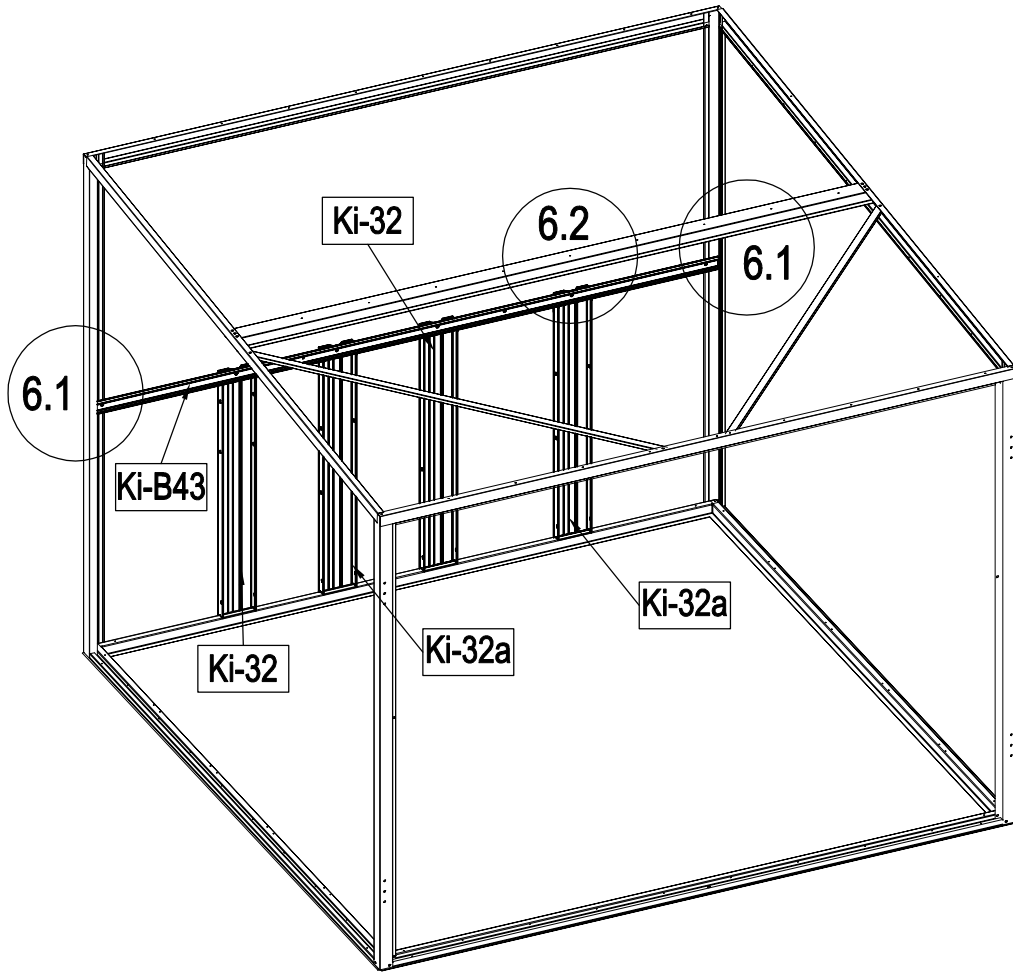

	Ki-B43	1
	Ki-32	2
	Ki-32a	2
	Ki-B45	6

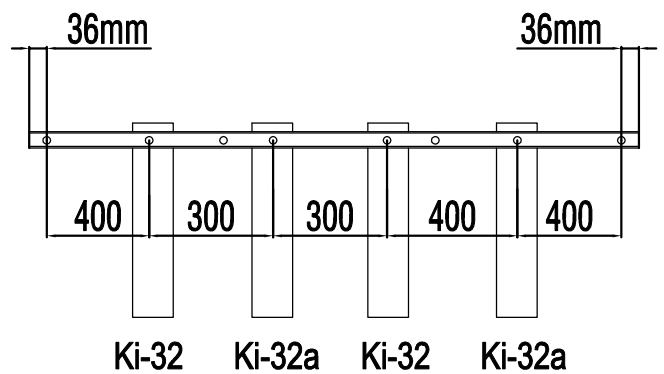

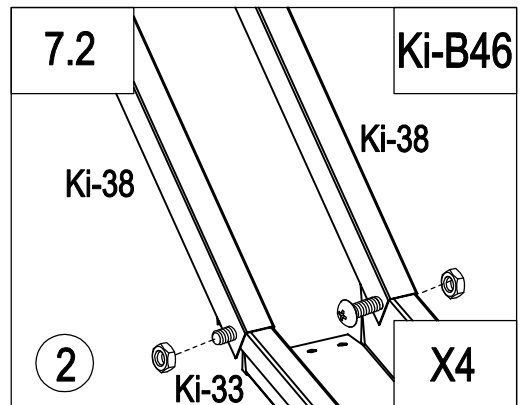
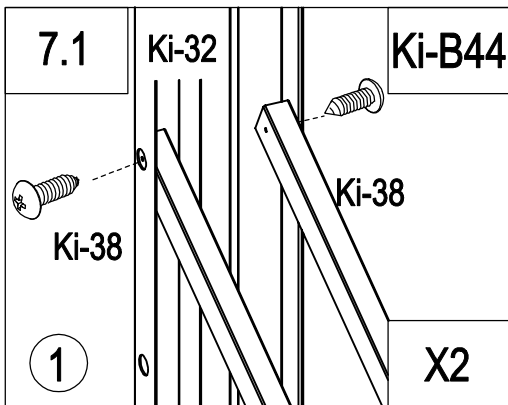
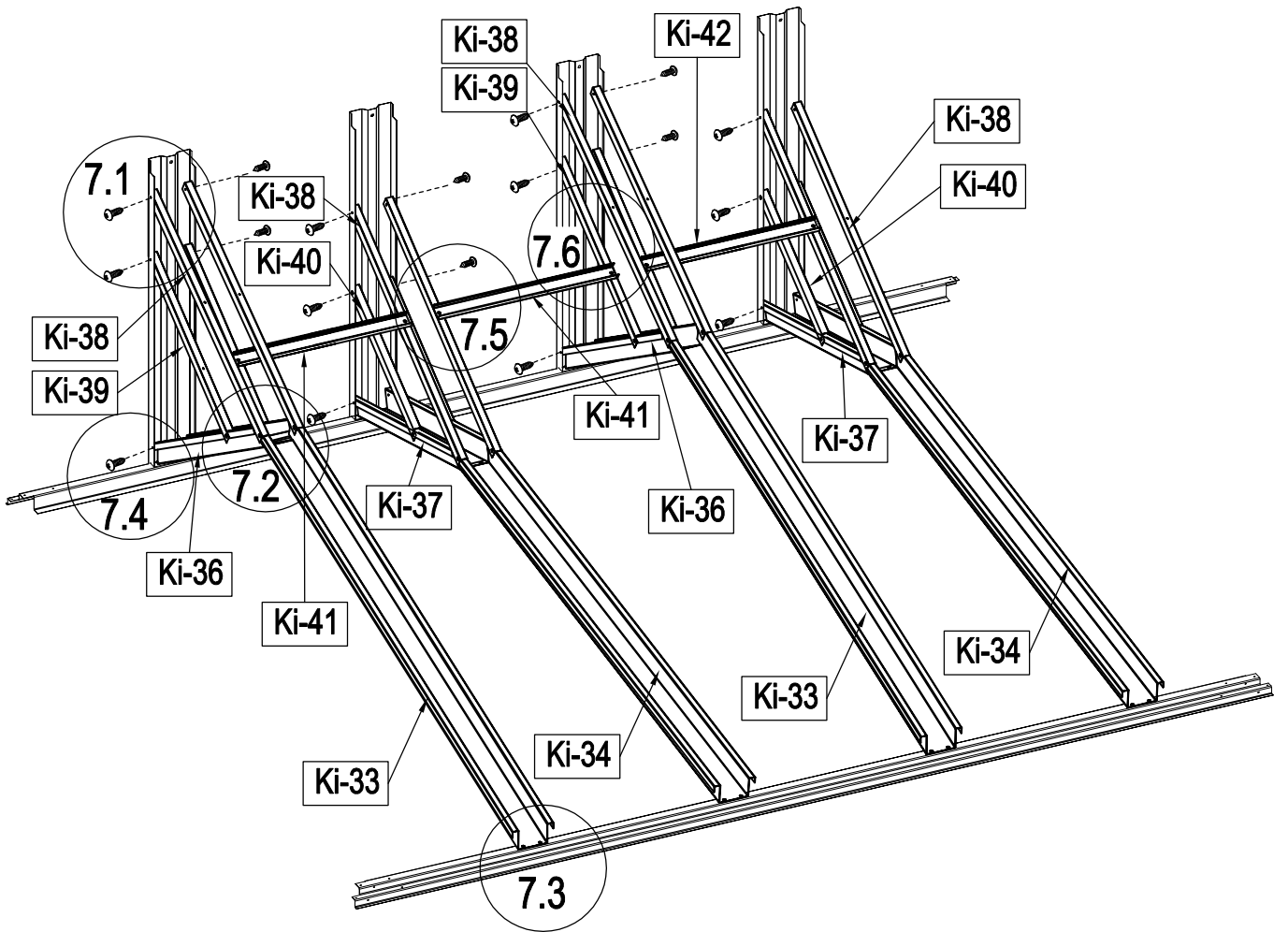

	Ki-33	2
	Ki-34	2
	Ki-36	2
	Ki-37	2
	Ki-38	8
	Ki-39	4

	Ki-40	4
	Ki-41	2
	Ki-42	1
	Ki-B44	46
	Ki-B45	8

	Ki-B46	16
--	--------	----

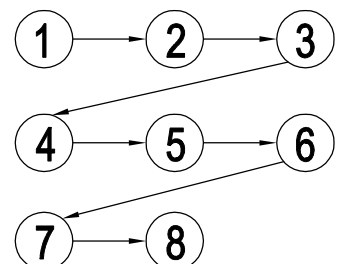

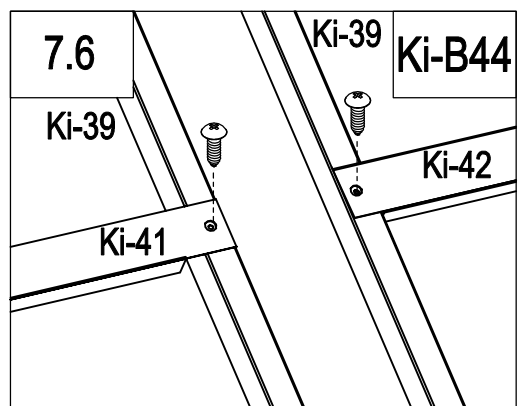
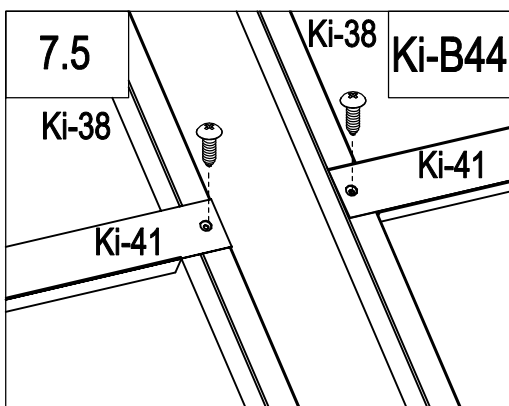
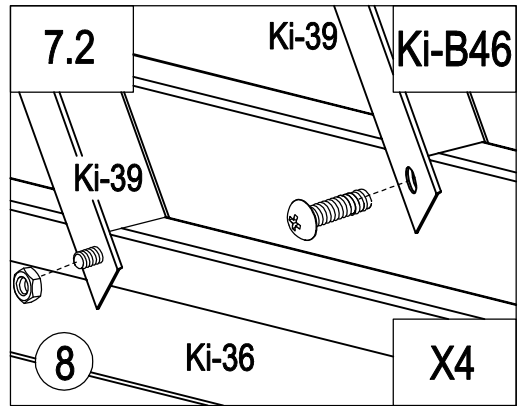
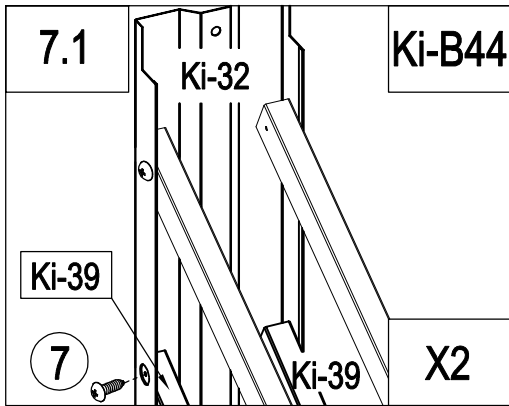
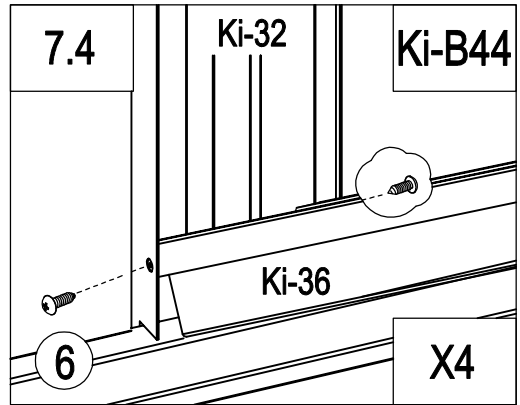
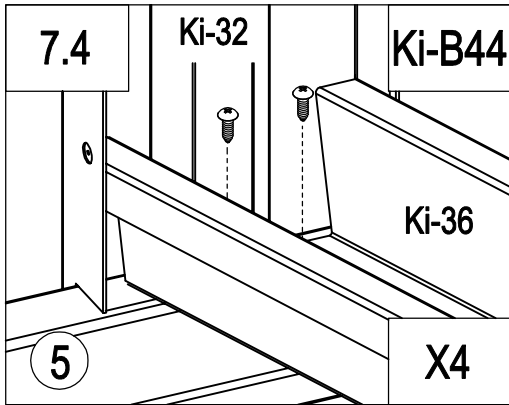
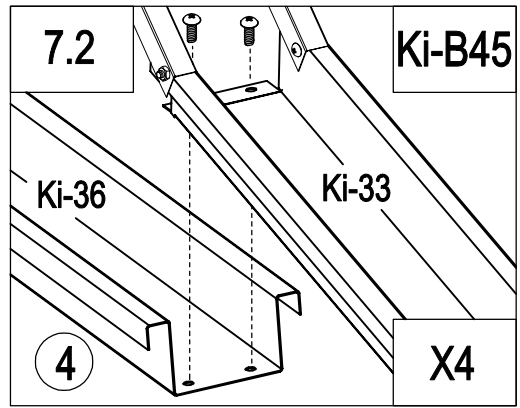
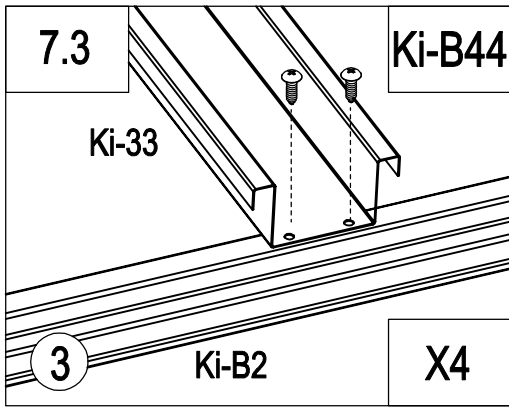

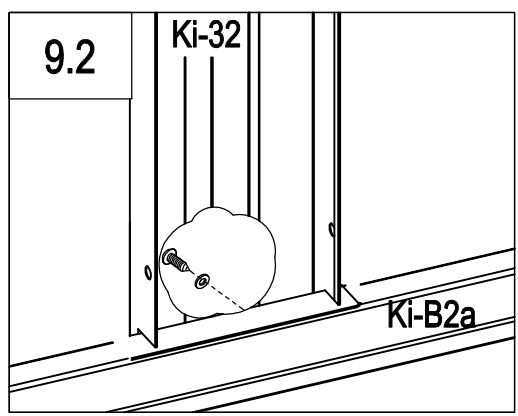
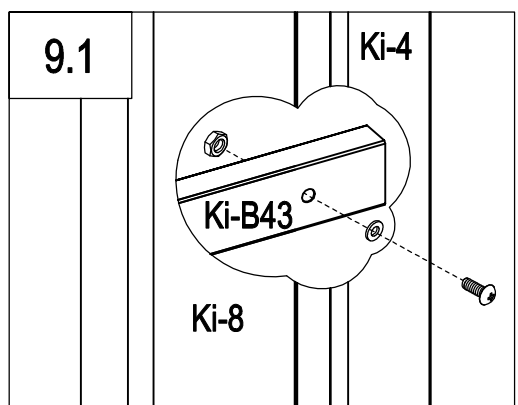
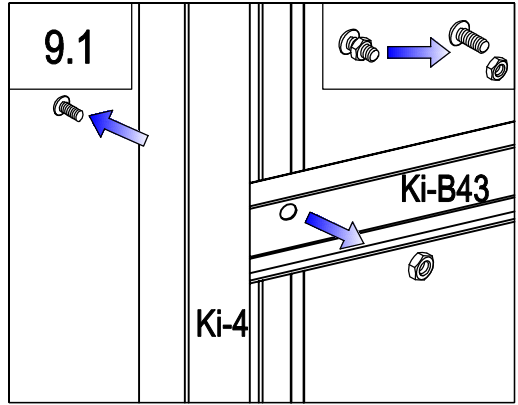
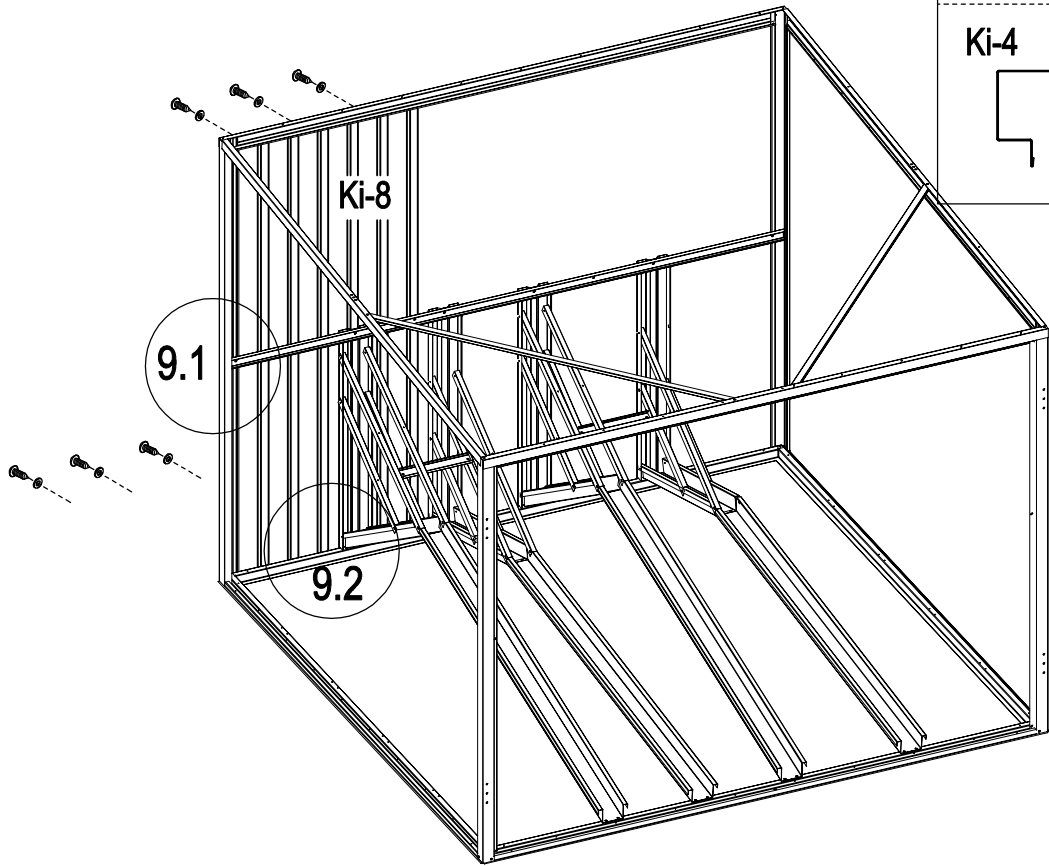
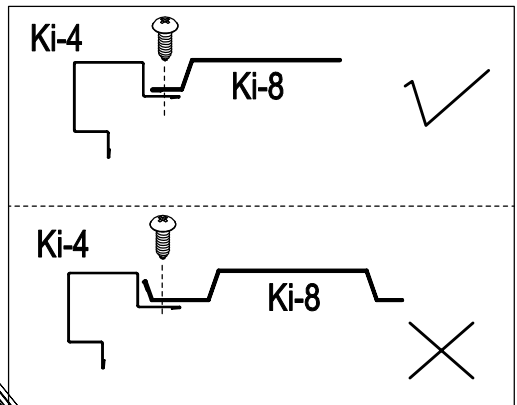



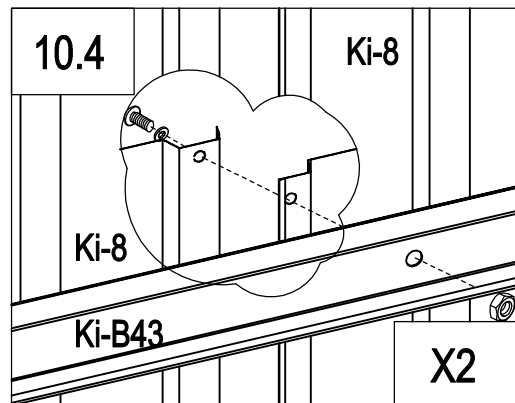
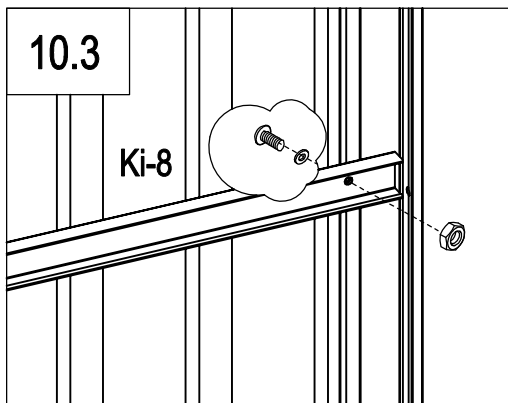
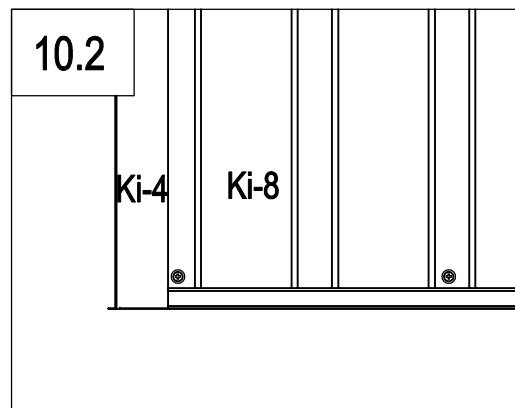
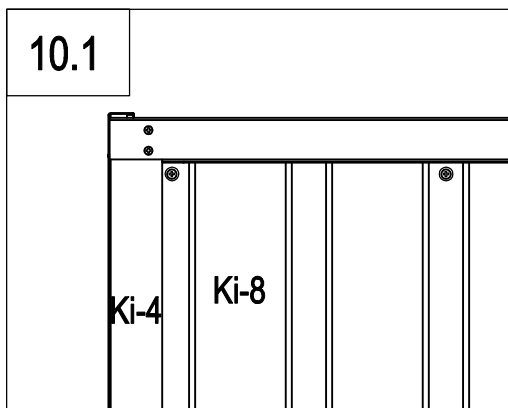
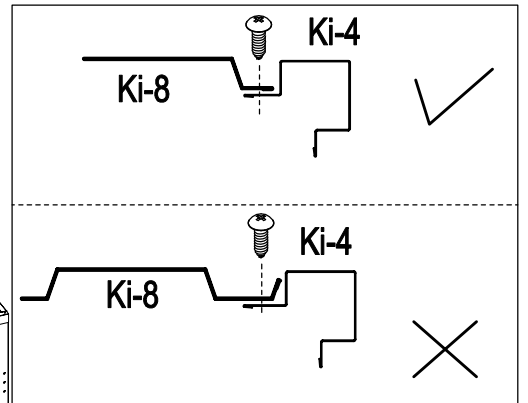
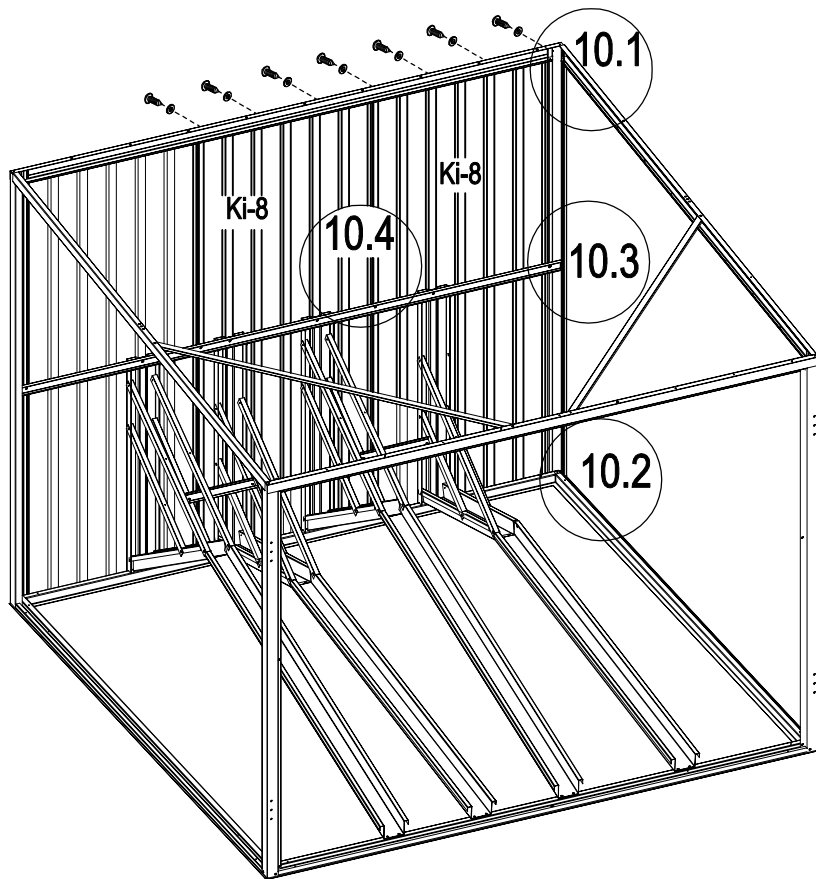

	Ki-8	1
	Ki-B44	6
	Ki-B50	7



	Ki-8	2
	Ki-B44	14
	Ki-B45	2

	Ki-B50	17
---	--------	----

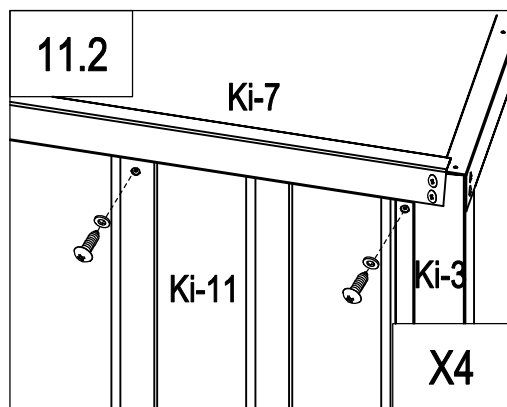
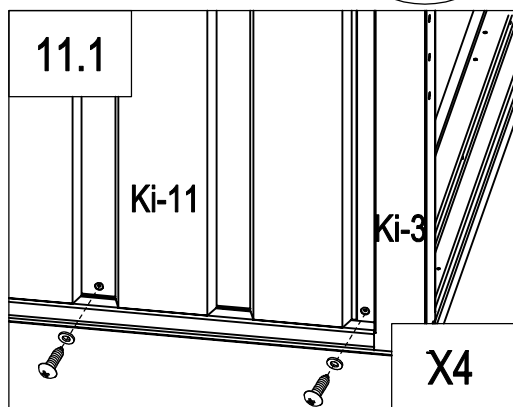
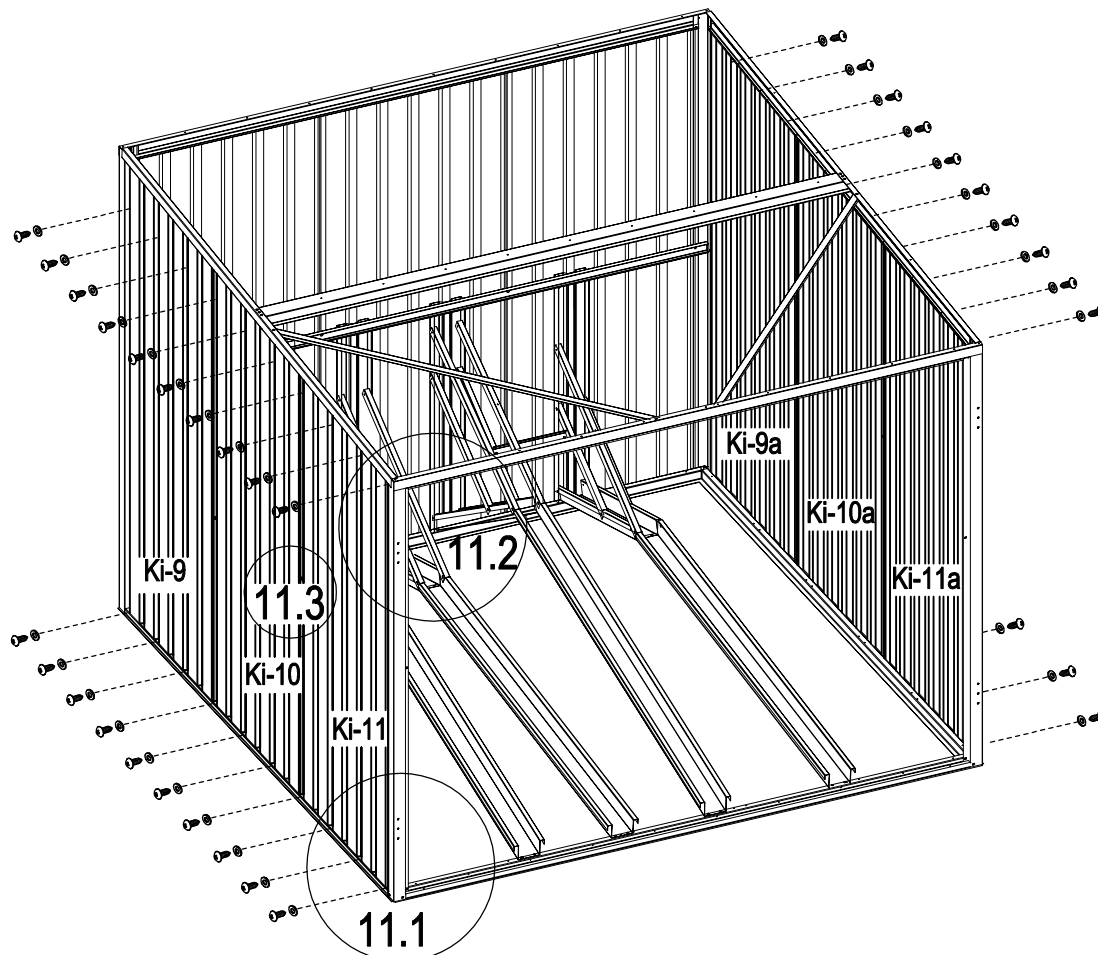



	Ki-9	1
	Ki-10	1
	Ki-11	1
	Ki-9a	1
	Ki-10a	1
	Ki-11a	1
	Ki-B44	40

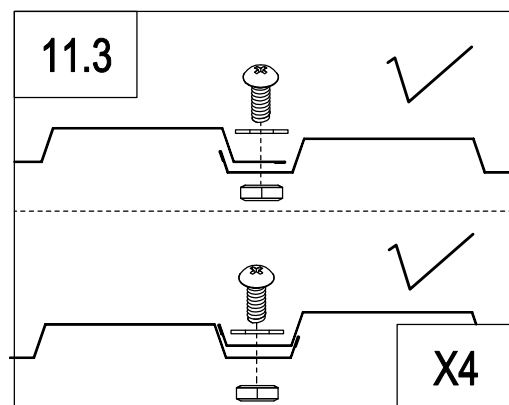

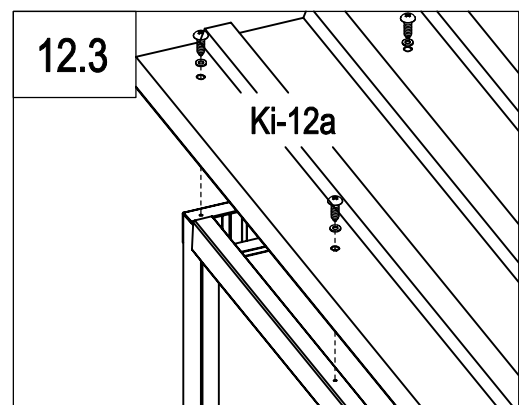
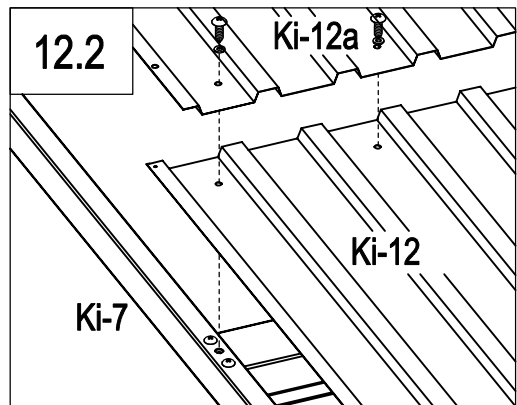
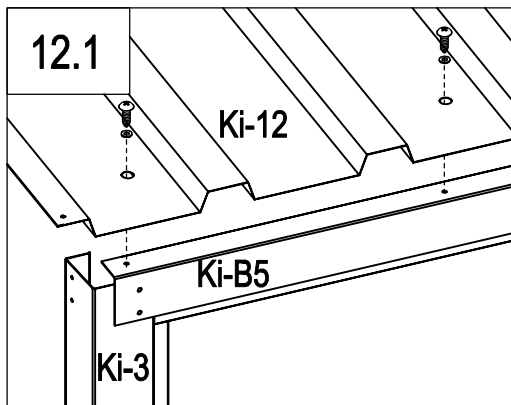
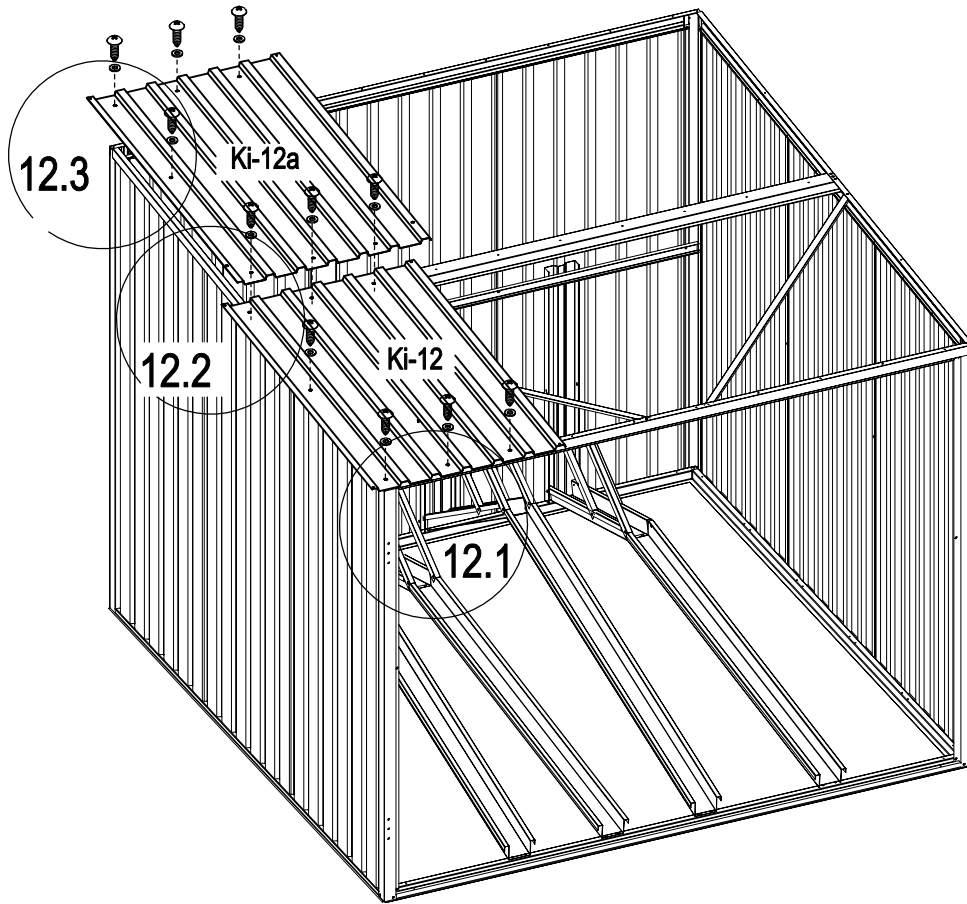

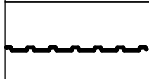
	Ki-B45	8
	Ki-B50	48



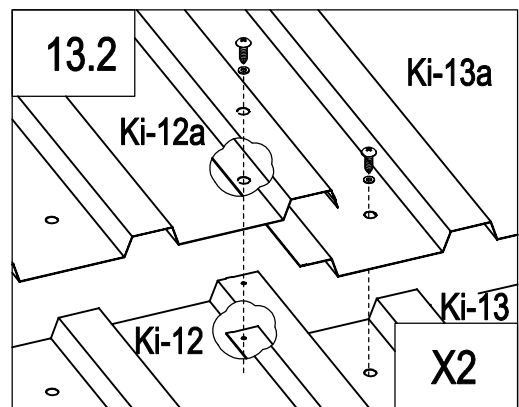
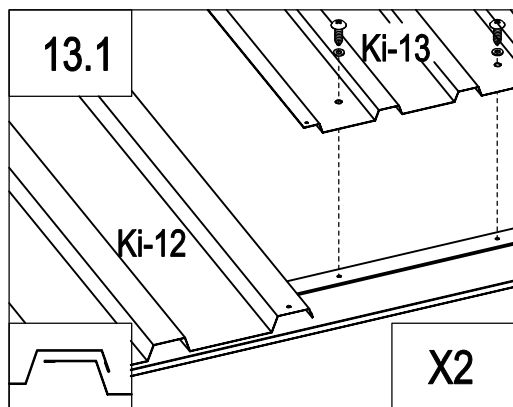
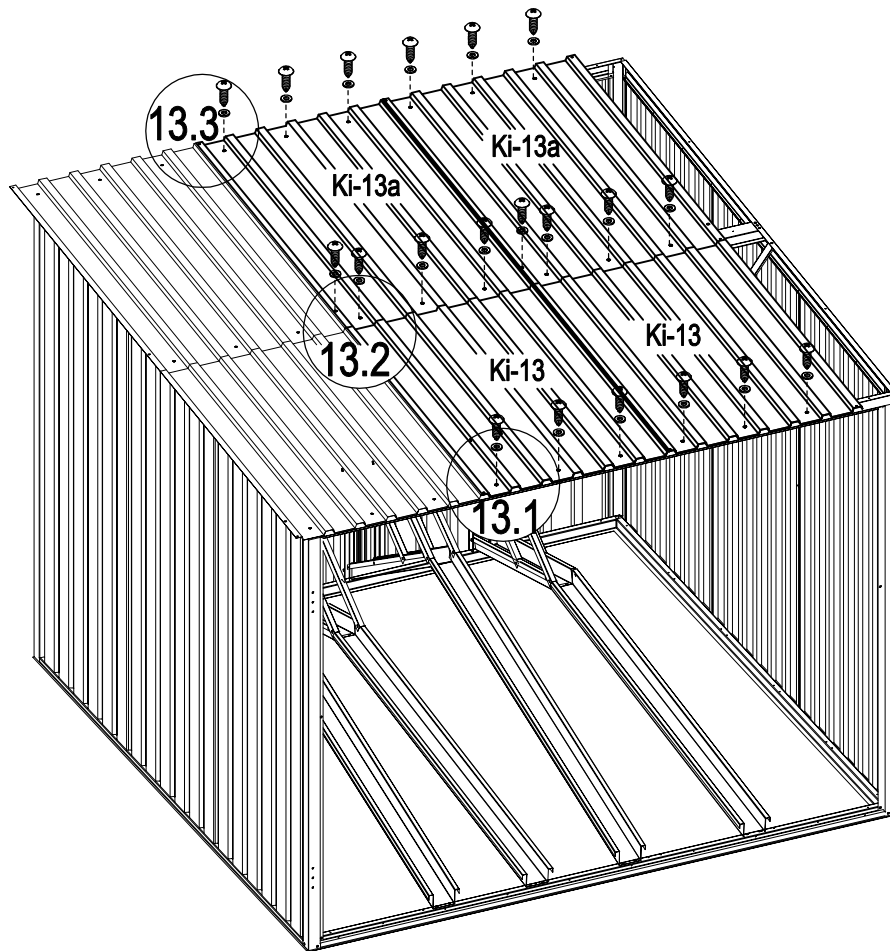





	Ki-12	1
	Ki-12a	1
	Ki-B44	11
	Ki-B50	11

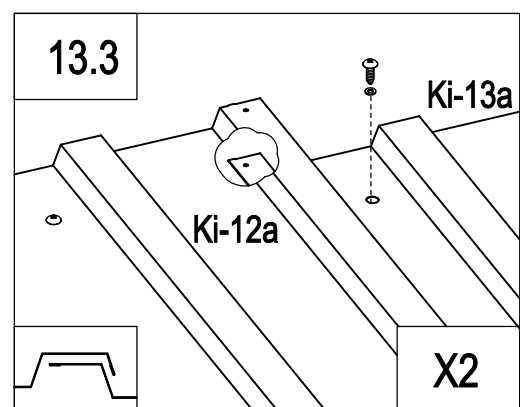

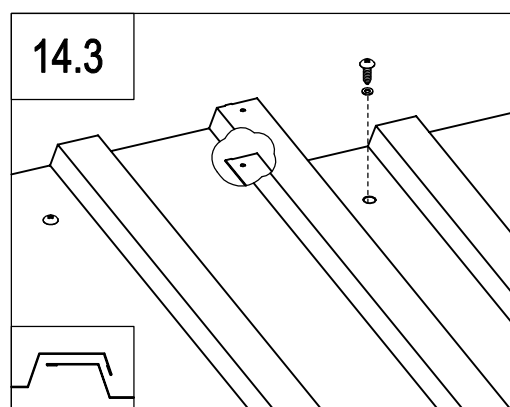
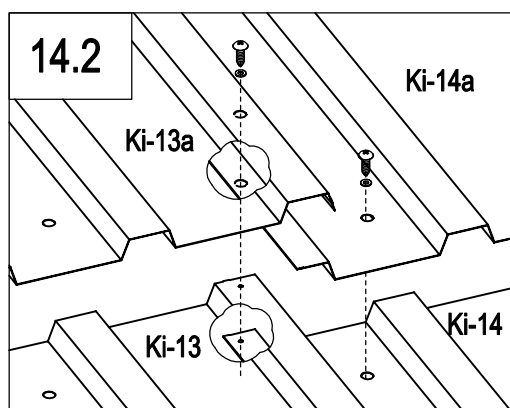
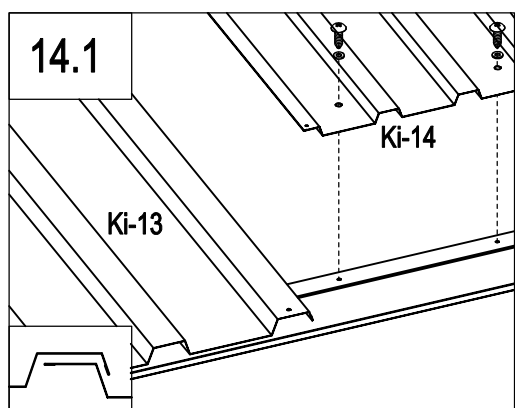
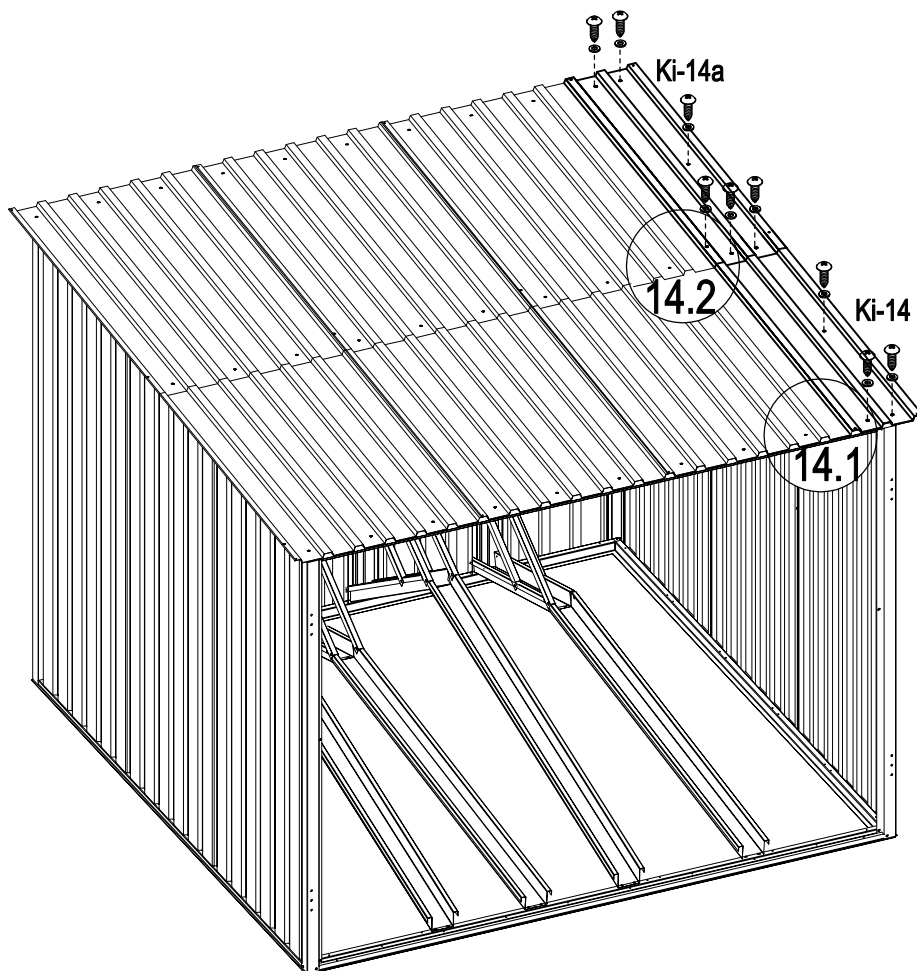
	Ki-13	2
	Ki-13a	2
	Ki-B44	20
	Ki-B50	20





	Ki-14	1
	Ki-14a	1
	Ki-B44	9
	Ki-B50	9

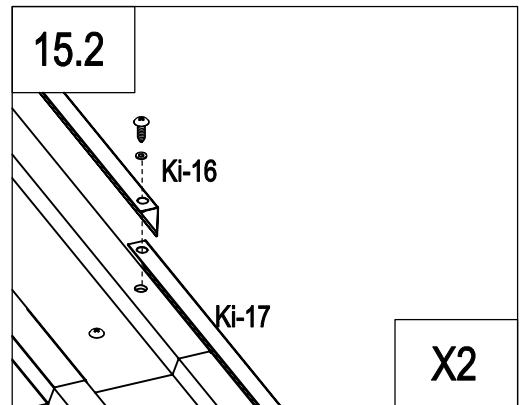
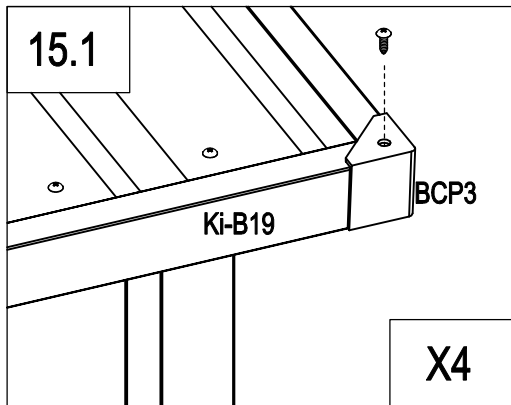
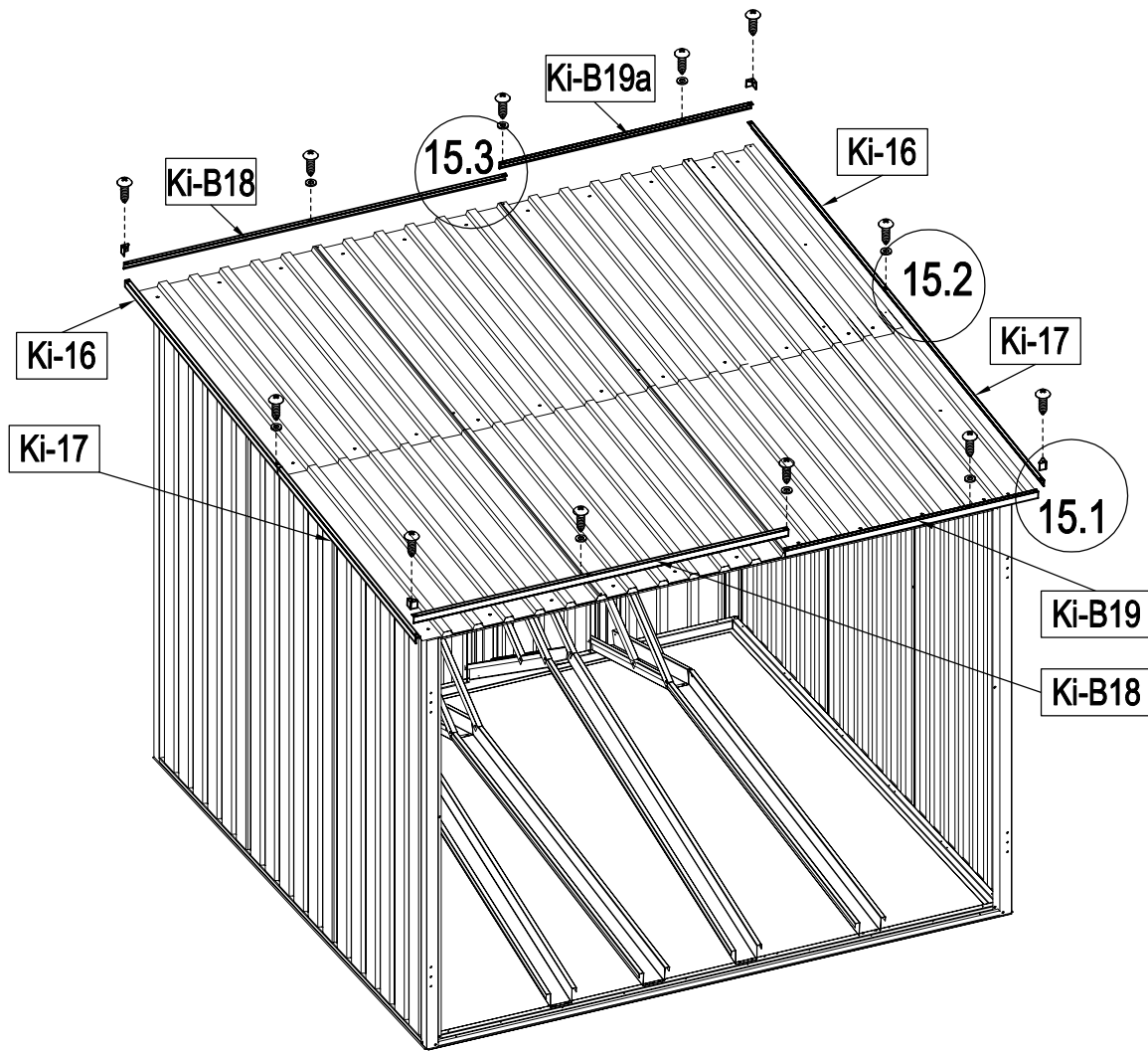

└	Ki-16	2		Ki-B44	12
└	Ki-17	2		Ki-B50	8
└	Ki-B18	2			
└	Ki-B19	1			
└	Ki-B19a	1			
	BCP3	4			

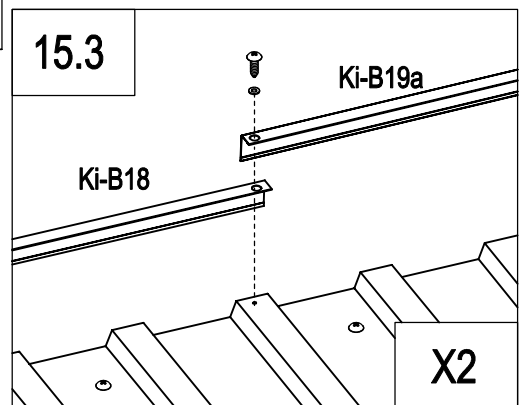

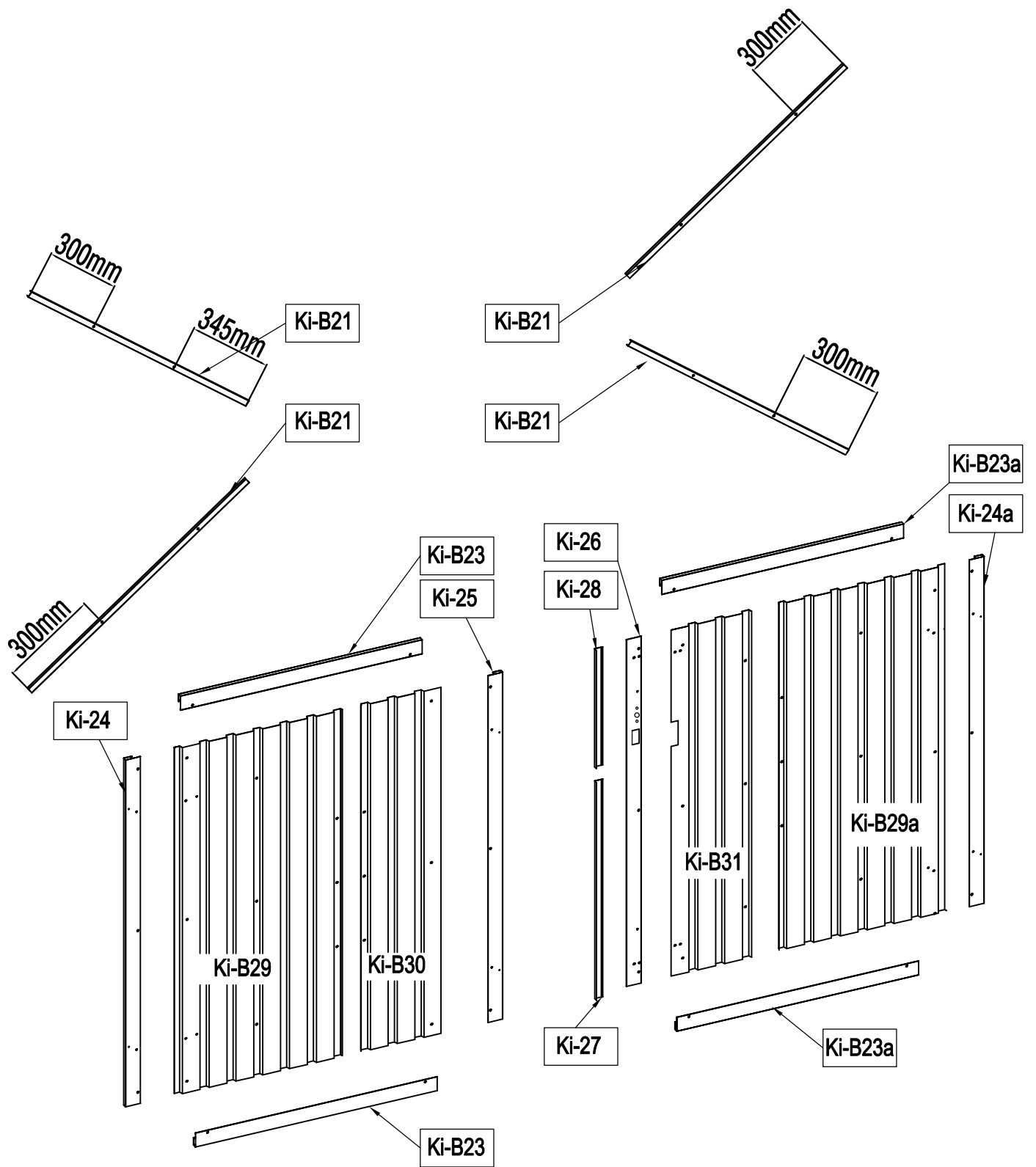

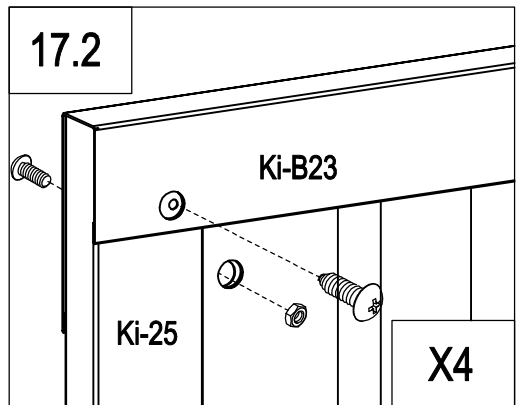
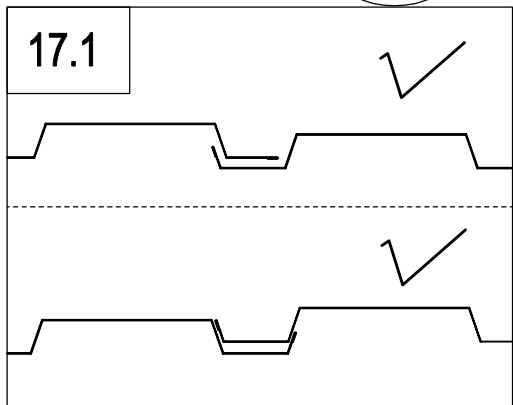
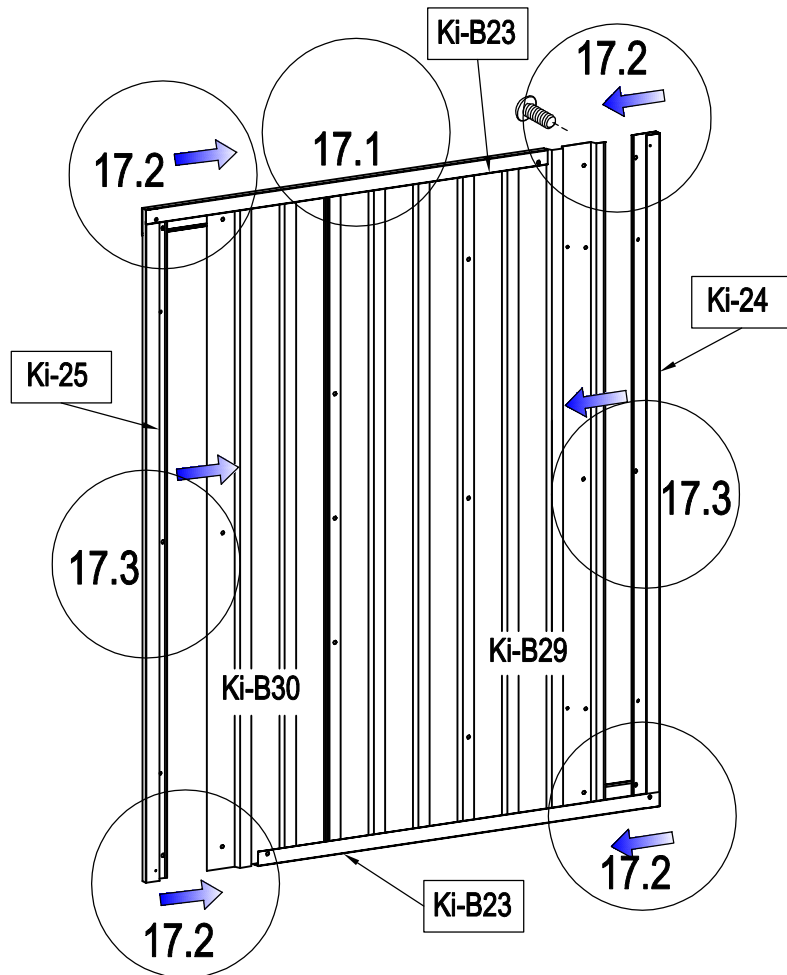

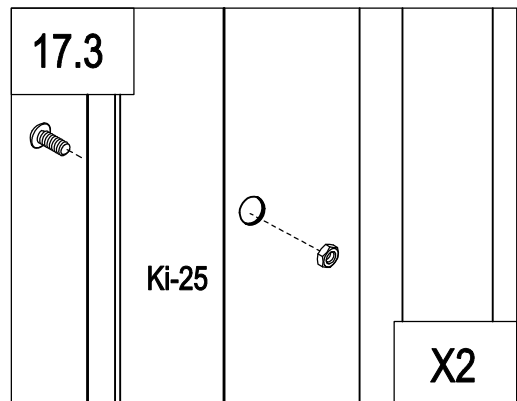

	Ki-B29	1
	Ki-B30	1
	Ki-B23	2
	Ki-24	1
	Ki-25	1
	Ki-B44	4
	Ki-B45	6

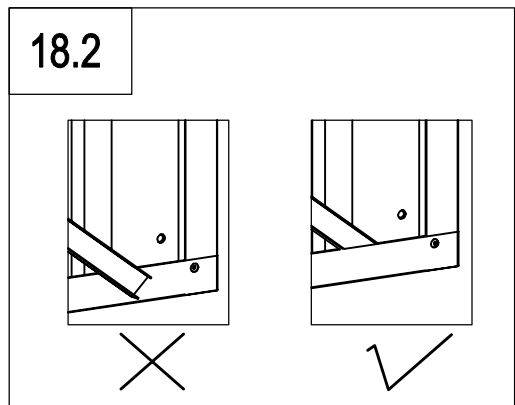
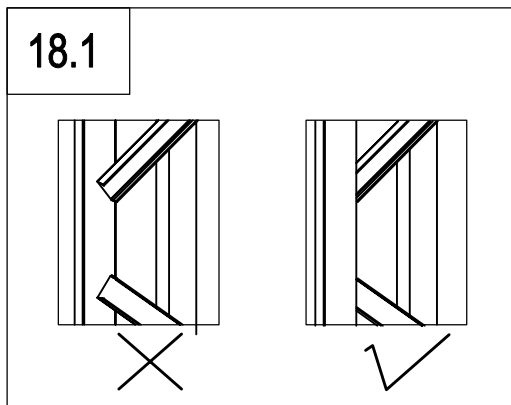
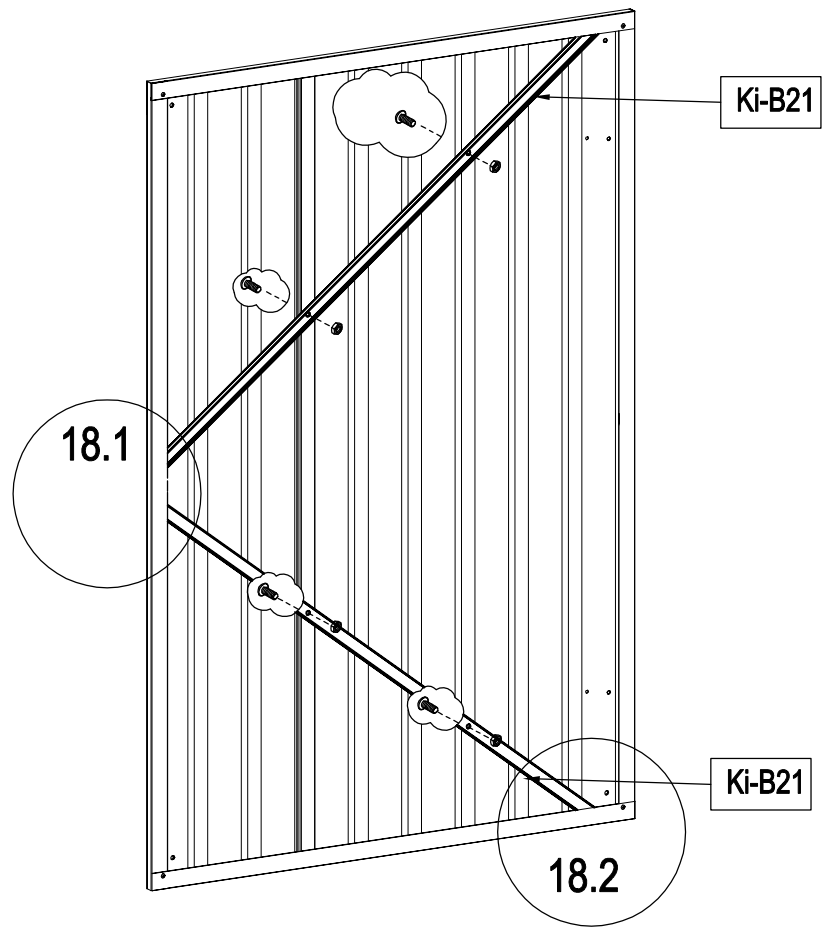



	Ki-B21	2
	Ki-B45	6

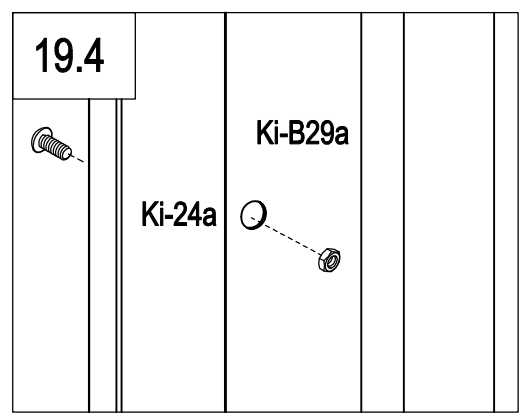
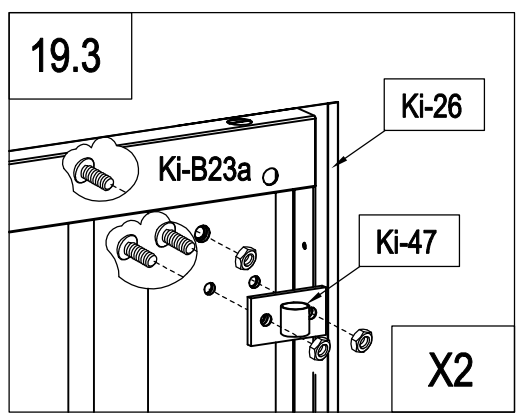
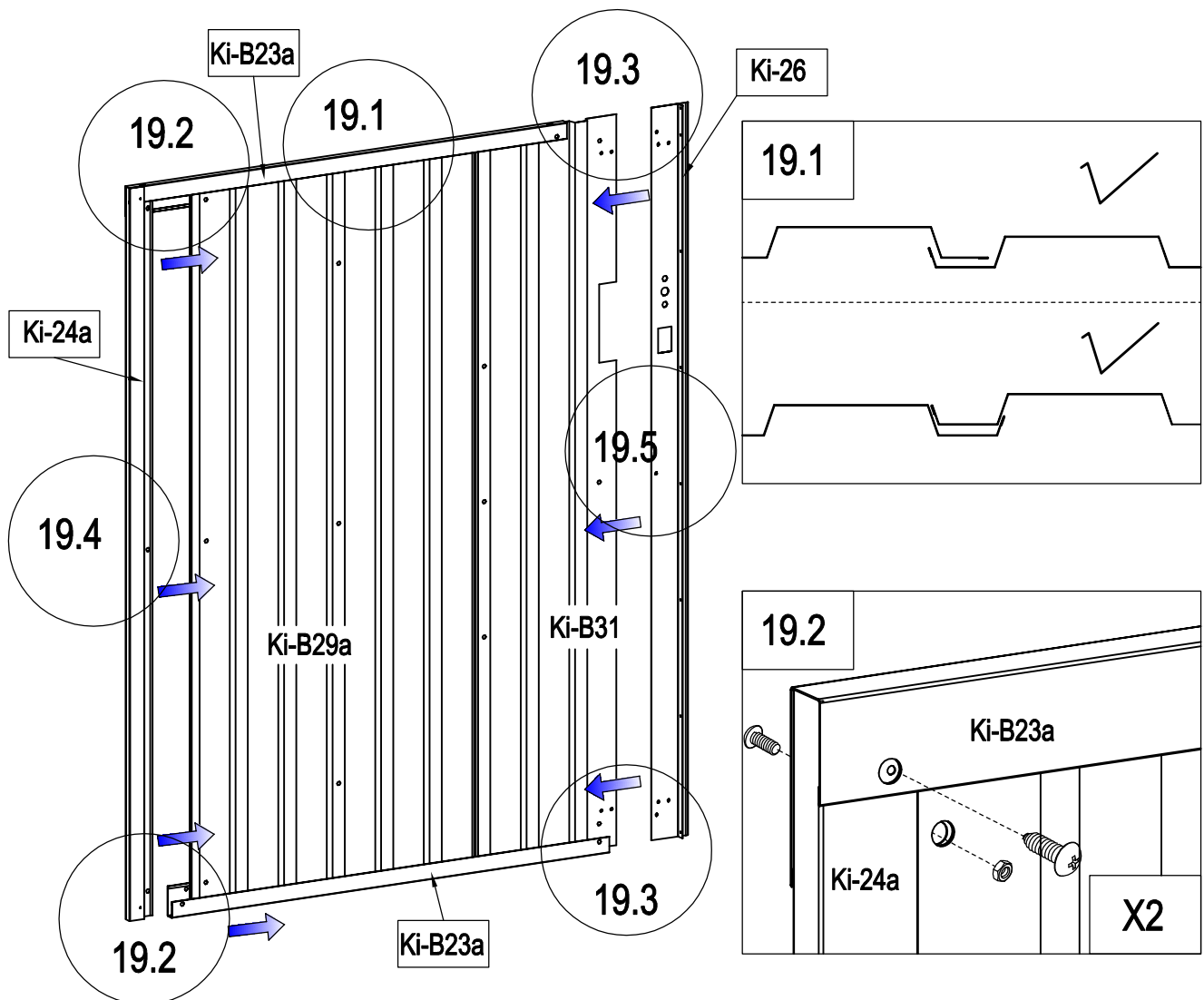

	Ki-B29a	1		Ki-B44	2
	Ki-B31	1		Ki-B45	10
	Ki-B23a	2		Ki-47	2
	Ki-24a	1			
	Ki-26	1			

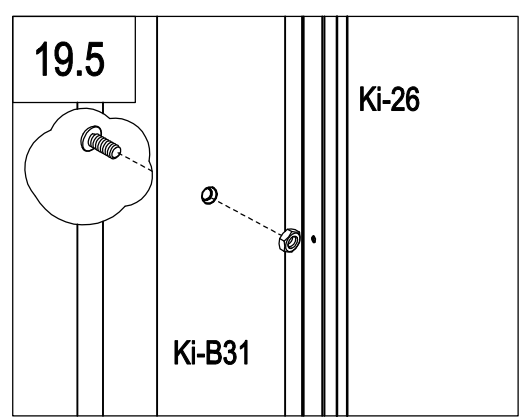

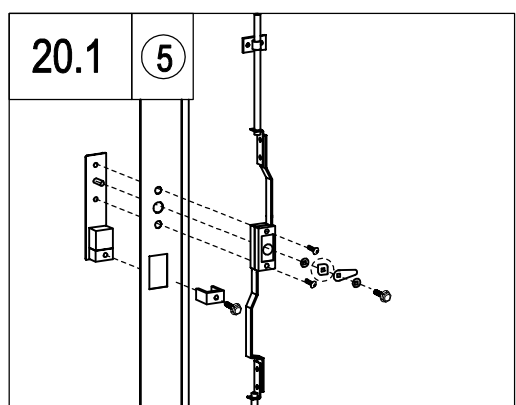
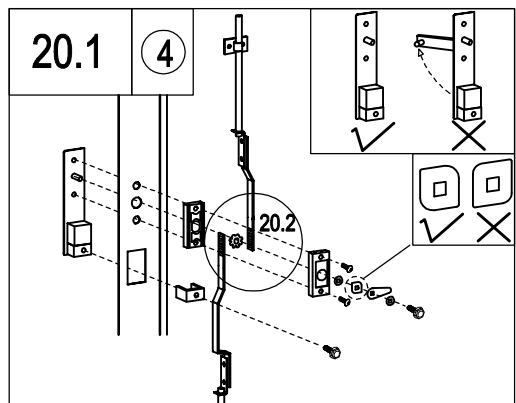
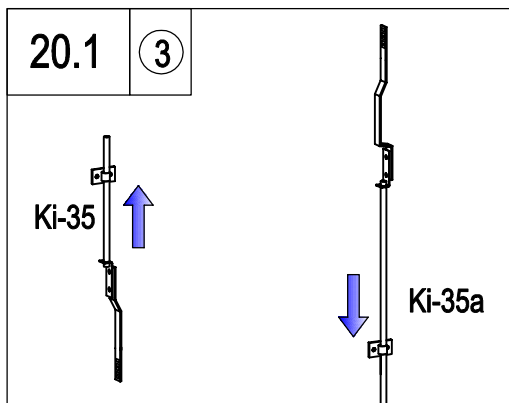
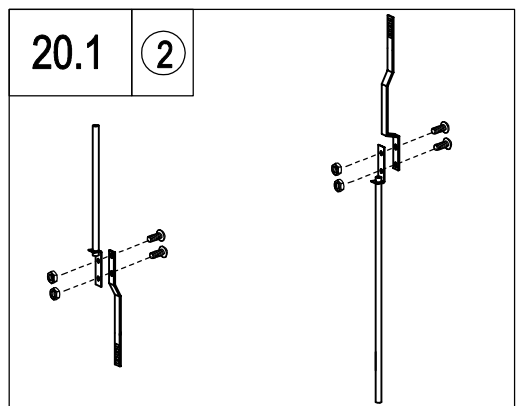
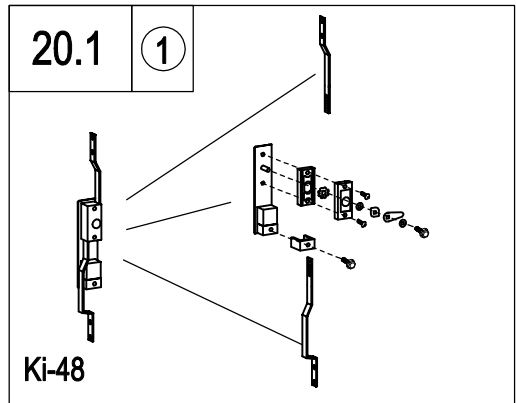
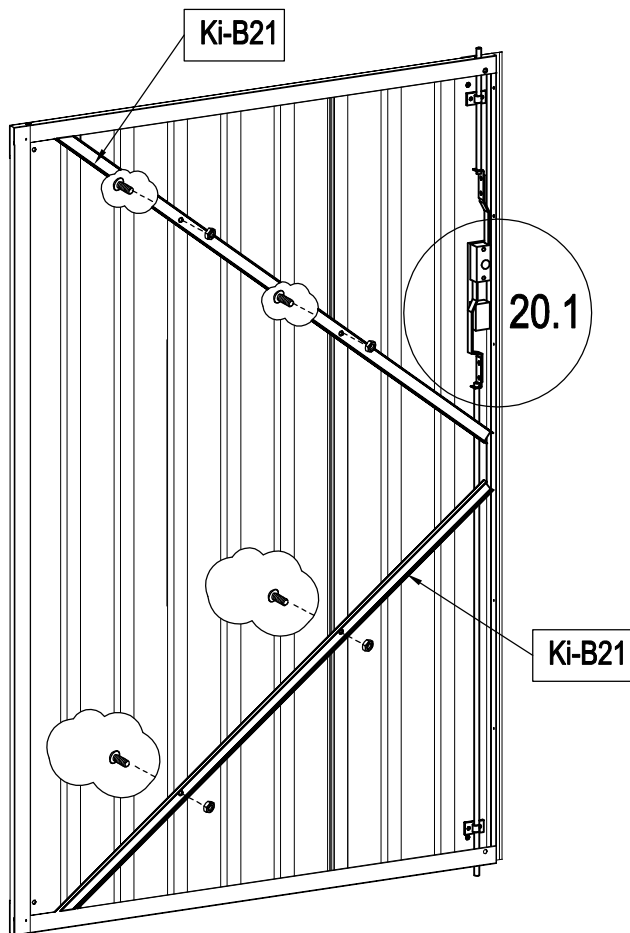



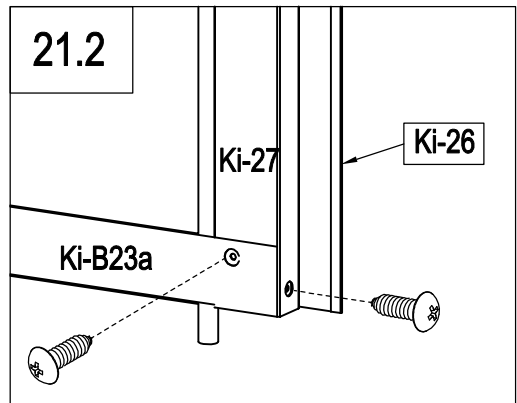
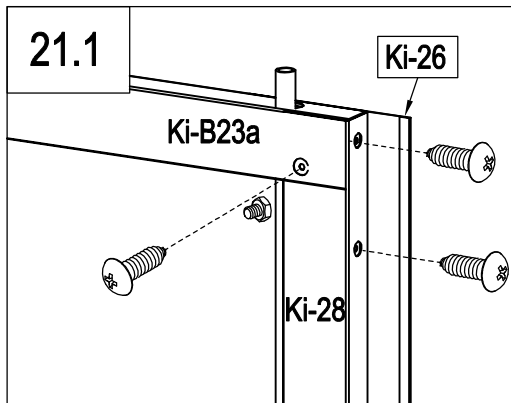
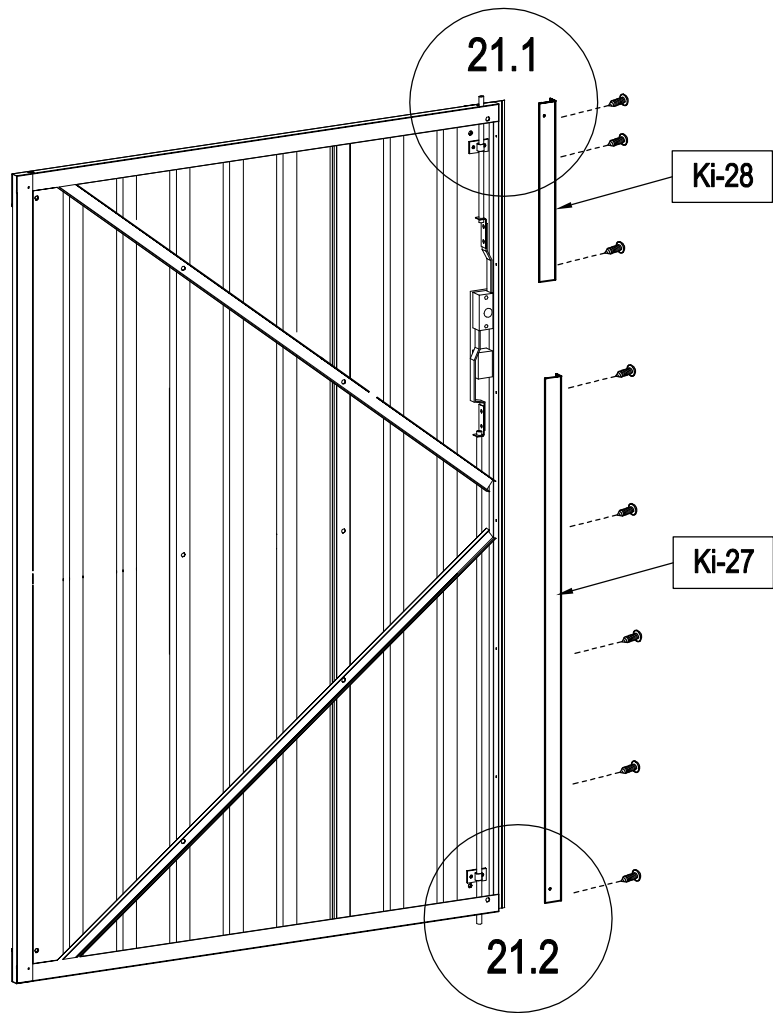

	Ki-35	1
	Ki-35a	1
	Ki-B21	2
	Ki-B45	10

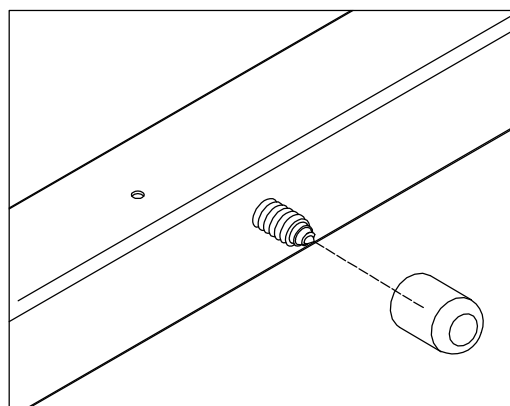
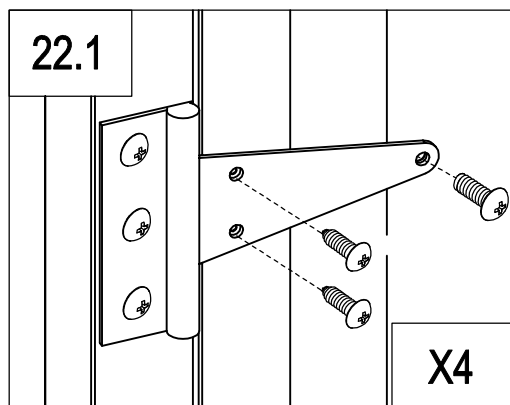
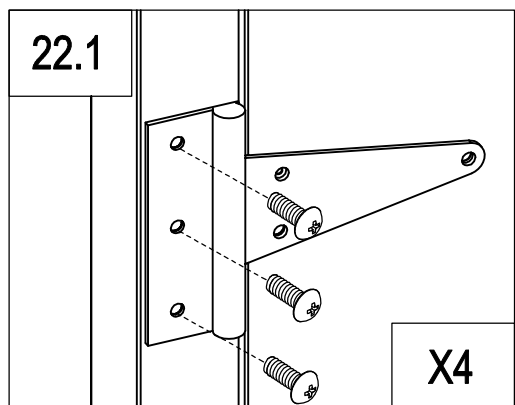
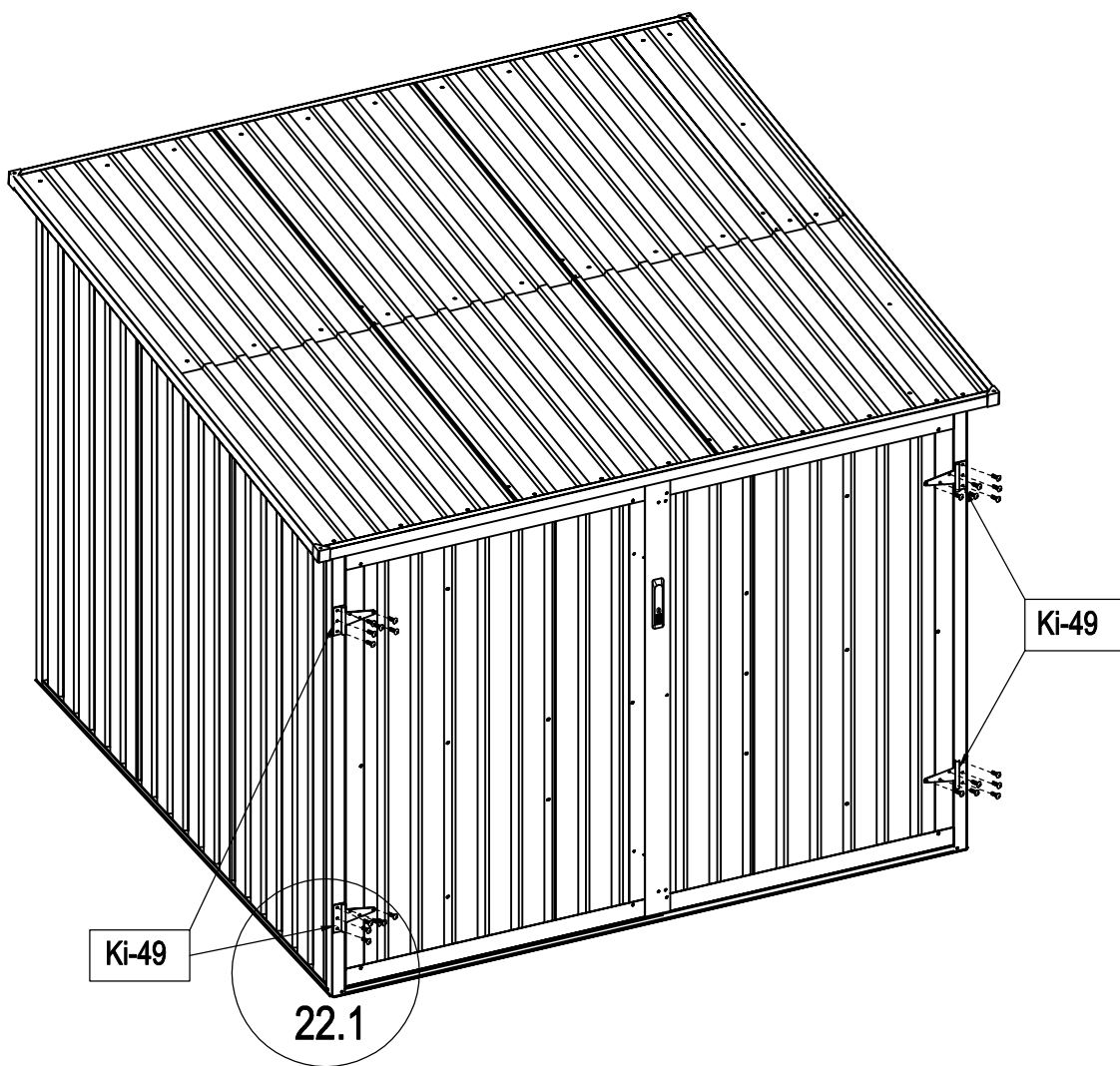

└	Ki-27	1
└	Ki-28	1
	Ki-B44	10

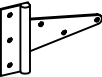

	Ki-51	20
	Ki-49	4
	Ki-B44	4
	Ki-B45	24