

# MyChair&Wavy

Baby Chair and Bouncer

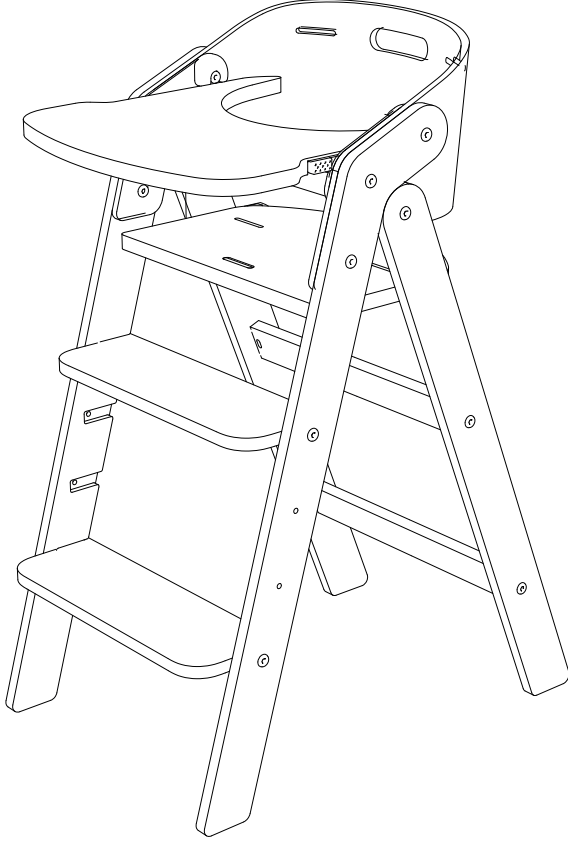

• **mamatoyz** •

Manufacturer / Üretici

**BUBA TASARIM SAN. TIC. A.Ş**

İnönü Mah. 363. Sk. No:1/23 Esenyurt / İstanbul / Türkiye

+90 212 67171 73

info@mamatoyz.com

www.mamatoyz.com

@mamatoyz

mamatoyz



DESIGNED  
& MADE  
IN  
TURKEY

UK  
CA



intertek  
Total Quality Assured.

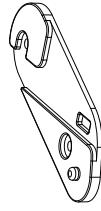
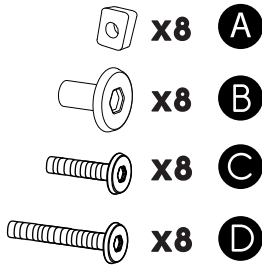

X2 E

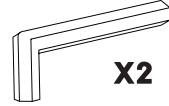

X2

## TR UYARI!

- 6 ay 15 yaş arası çocuklar için uygundur.
- Bir yetişkin tarafından çizimdeki gibi montaj yapılmalıdır.
- Çocukları ambalaj malzemesinde uzak tutunuz, aksi halde boğulma tehlikesi vardır.
- Bir yetişkin gözetiminde kullanılmalıdır.
- Birden fazla çocuğun oturmasına izin verilmemelidir.
- Ürün yol kenarında, yokuşta, yollarda, ıslak zeminlerde kullanılmamalıdır.

**EASY  
SETUP**  
**QR CODE**  
**KOLAY  
KURULUM**



## ENG WARNING!

- Suitable for children aged 6 months to 15 years.
- Assembly should be done by an adult as in the drawing.
- Keep children away from the packaging material, otherwise there is a danger of suffocation.
- Should be used under adult supervision.
- More than one child should not be allowed to sit.
- The product should not be used on roadsides, slopes, roads or wet surfaces.

## FR ATTENTION!

- Convient aux enfants de 6 mois à 15 ans.
- L'assemblage doit être fait par un adulte comme sur le dessin.
- Tenez les enfants éloignés du matériel d'emballage, sinon il y a un risque d'étouffement.
- Doit être utilisé sous la surveillance d'un adulte.
- Plus d'un enfant ne devrait pas être autorisé à s'asseoir.
- Le produit ne doit pas être utilisé sur les bords de route, les pentes, les routes ou les surfaces mouillées.

## IT ATTENZIONE!

- Adatto a bambini dai 6 mesi ai 15 anni.
- Il montaggio deve essere eseguito da un adulto come nel disegno.
- Tenere i bambini lontani dal materiale di imballaggio, altrimenti c'è pericolo di soffocamento.
- Deve essere utilizzato sotto la supervisione di un adulto.
- Non dovrebbe essere permesso a più di un bambino di sedersi.
- Il prodotto non deve essere utilizzato su bordi stradali, pendii, strade o superfici bagnate.

## ES ATENCIÓN!

- Apto para niños de 6 meses a 15 años.
- El montaje debe ser realizado por un adulto como en el dibujo.
- Mantenga a los niños alejados del material de embalaje, de lo contrario hay peligro de asfixia.
- Debe utilizarse bajo la supervisión de un adulto.
- No se debe permitir que se siente más de un niño.
- El producto no debe utilizarse en bordes de carreteras, pendientes, carreteras o superficies mojadas.

## DE ACHTUNG!

- Geeignet für Kinder im Alter von 6 Monaten bis 15 Jahren.
- Die Montage sollte wie in der Zeichnung von einem Erwachsenen durchgeführt werden.
- Andernfalls Kinder vom Verpackungsmaterial fernhalten es besteht Erstickungsgefahr.
- Sollte unter Aufsicht von Erwachsenen verwendet werden.
- Es darf nicht mehr als ein Kind sitzen.
- Das Produkt sollte nicht an Straßenrändern, Hängen, Straßen oder nassen Oberflächen verwendet werden.

## P ATENÇÃO!

- Adequado para crianças de 6 meses a 15 anos.
- A montagem deve ser feita por um adulto conforme desenho.
- Mantenha as crianças afastadas do material de embalagem, caso contrário existe perigo de asfixia.
- Deve ser usado sob supervisão de um adulto.
- Não se deve permitir que mais de uma criança se sente.
- O produto não deve ser usado em beiras de estradas, encostas, estradas ou superfícies molhadas.

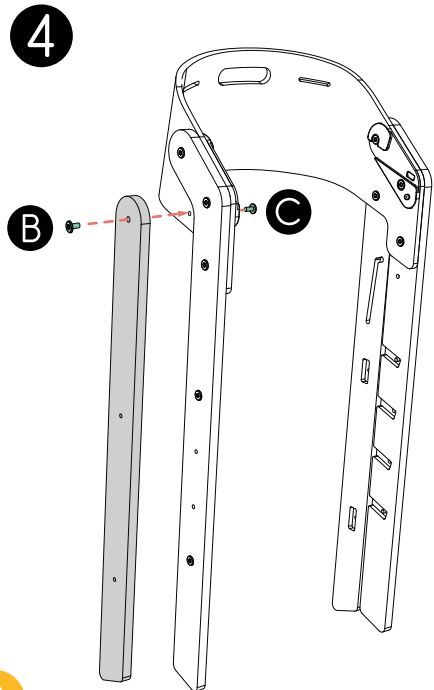
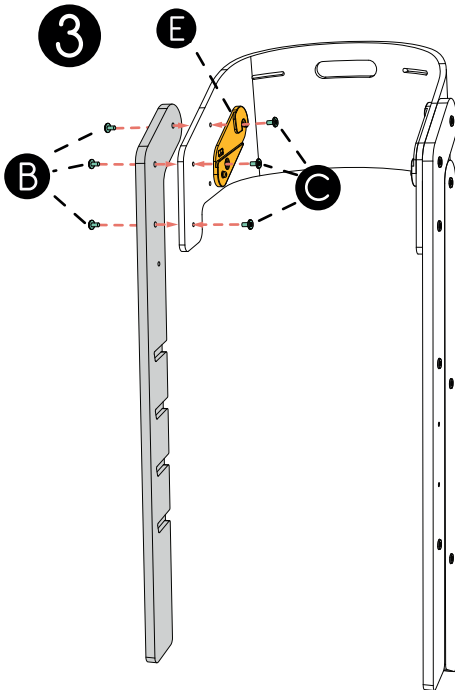
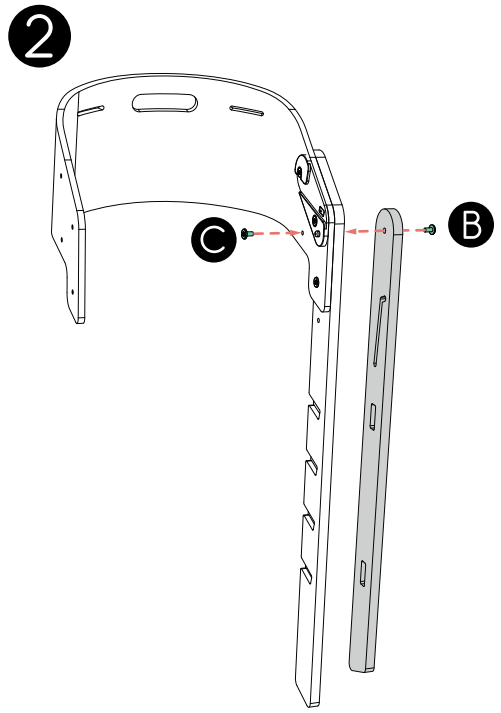
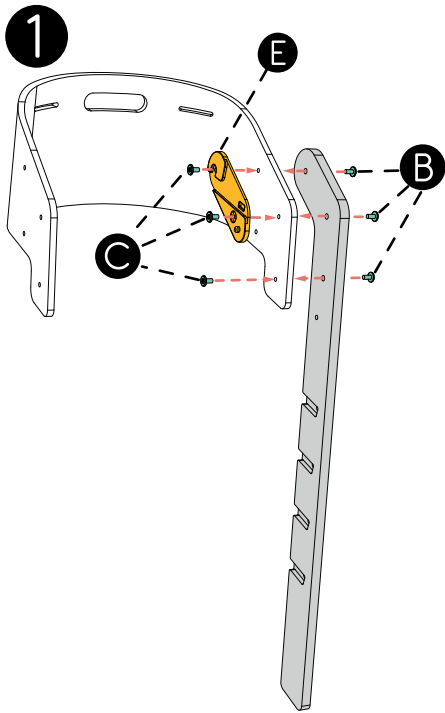

5

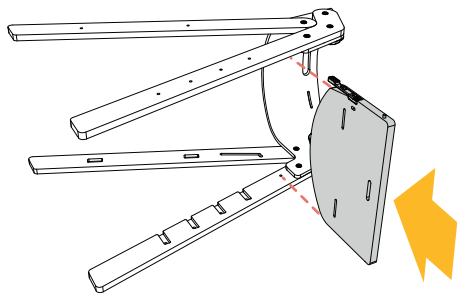

6

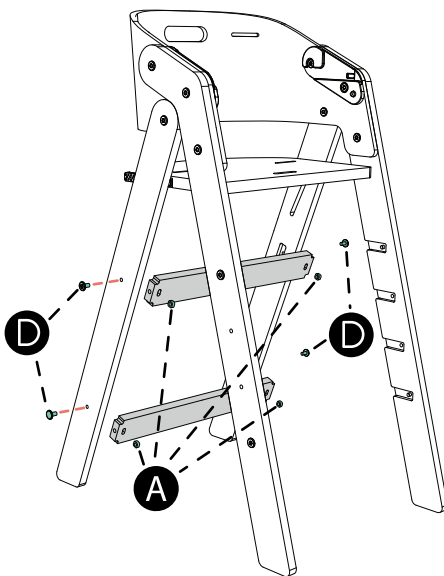

6.1

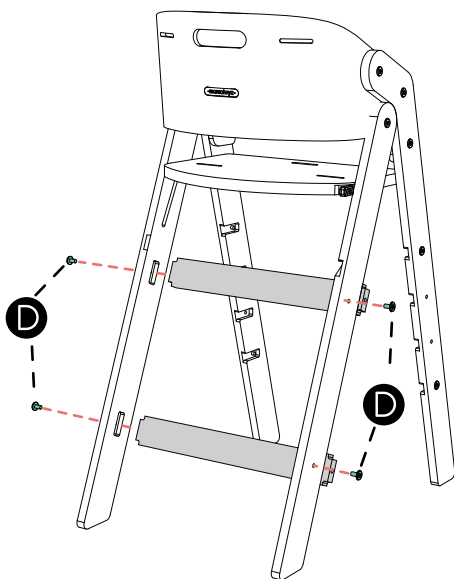

7

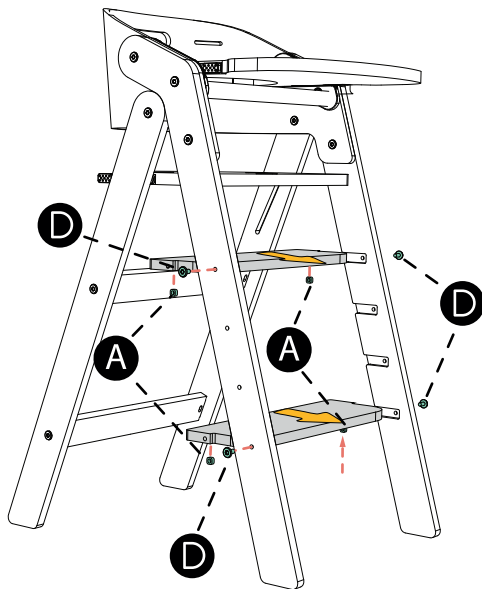

4