

FEISTOS



MONTAGE- & BETRIEBSANLEITUNG

Werkstatteinrichtung Apollo 15
FE991015



Abbildung und Anleitung zeigen nur eine Hälfte des Produkts:

Montieren Sie die Teile einmal wie abgebildet und einmal spiegelverkehrt und setzen Sie diese zusammen.



Warnung: Gefahr durch sehr hohes Gewicht!

Benutzen Sie zwei oder mehr Personen, um die Schränke und Spinde zu bewegen, zusammenzubauen oder zu installieren, um Rückenverletzungen zu vermeiden. Lassen Sie Kinder nicht unbeaufsichtigt in der Nähe von Schränken.



BEI FRAGEN, KONTAKTIEREN SIE UNSEREN KUNDENSERVICE:

50NRTH GmbH
Straßburgstraße 14-16
D-54516 Wittlich

service@50NRTH.com
+49 (0) 6571 95117-0

ANLEITUNG ZUSAMMENBAU ALLER BESTANDTEILE

BENÖTIGTES WERKZEUG



Sechskant
Schraubenschlüssel
passend zu Schrauben
(siehe unten)

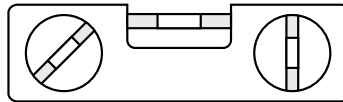

Wasserwaage



Akku-Schrauber
inkl. Bit-Satz
(siehe Schrauben)

SCHRAUBEN

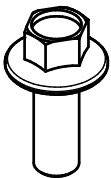

Sechskant-
Schraube
M6 x 16



Schrauben-
Mutter
M6

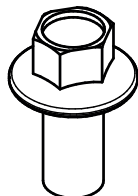

Sechskant-
Schraube
M8 x 16

ZUGEHÖRIGE ARBEITSPLATTE



53" Arbeitsplatte
Passt auf 2 Unterschränke

ZULÄSSIGES LADEGEWICHT

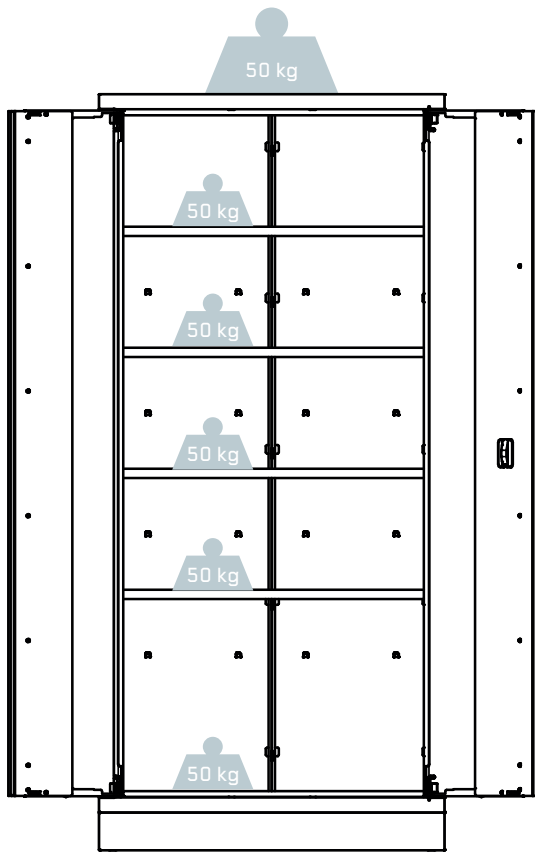

Doppeltür Schrank
max. 300 kg

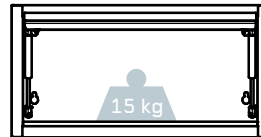

Hängeschrank
max. 15 kg

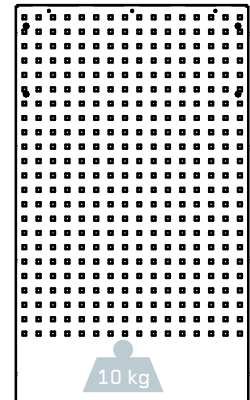

Rückwand
max. 10 kg

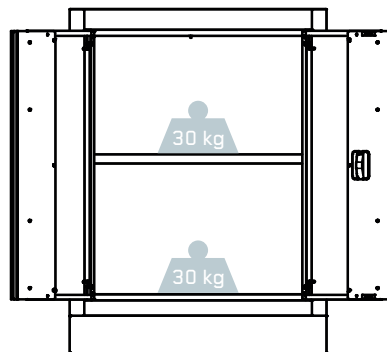

Basis
Unterschrank
max. 60 kg

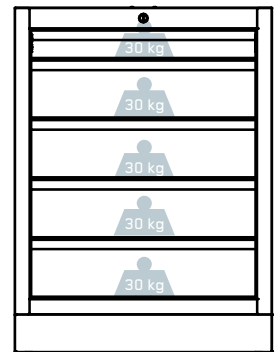

Unterschrank
mit Schubladen
max. 150 kg

1. SCHRITT Höhenverstellbare FüÙe

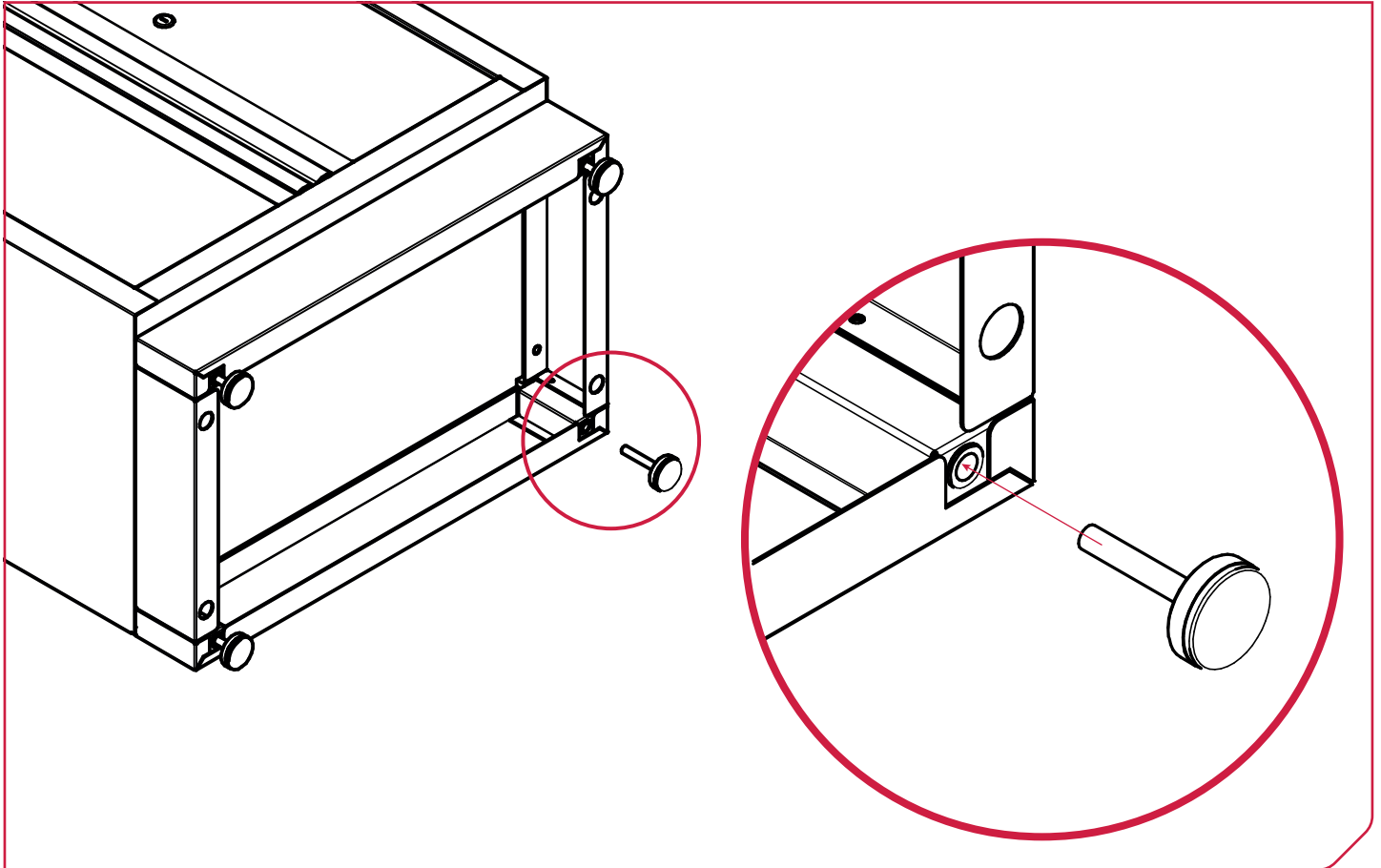

ZUTREFFENDE TEILE

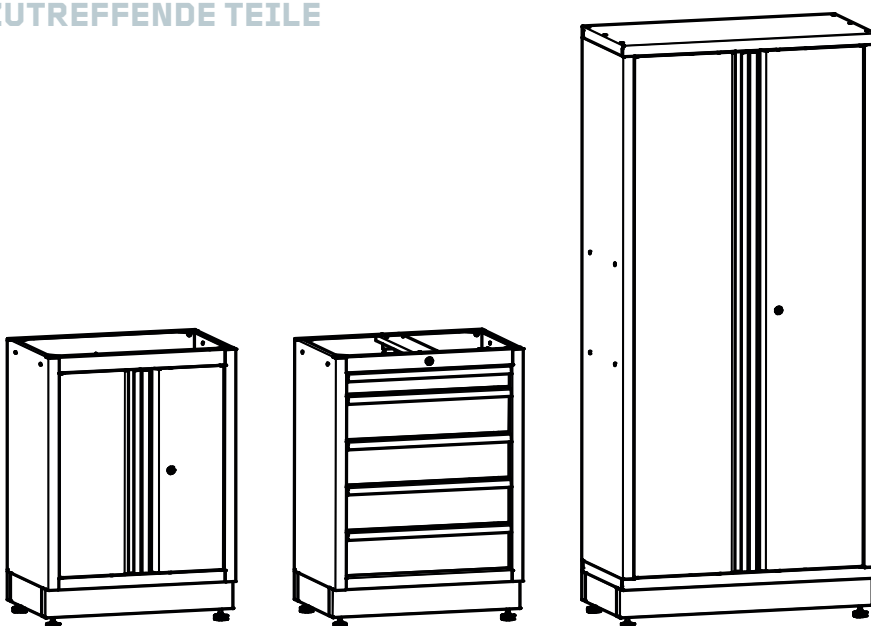

2. SCHRITT Rückwand Streben

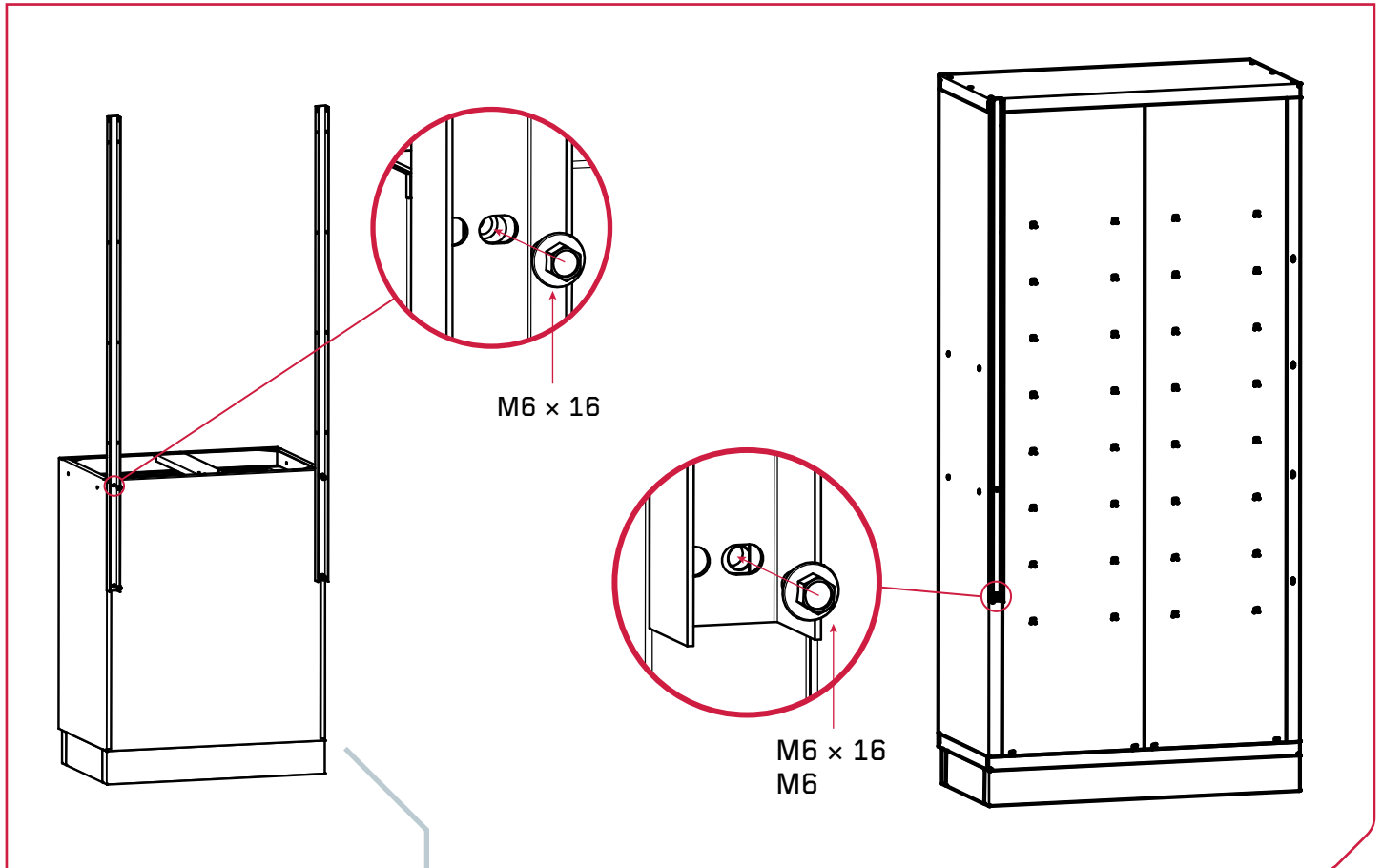

ZUTREFFENDE TEILE

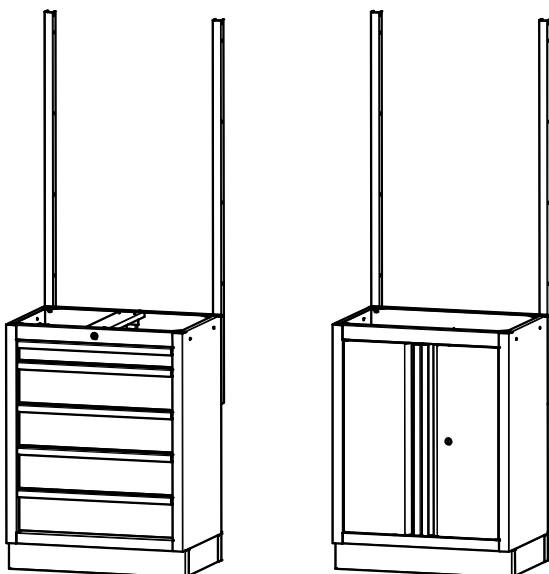

BENÖTIGTE SCHRAUBEN

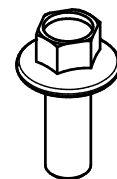

M6 x 16



M6

3. SCHRITT Rückwand Fläche

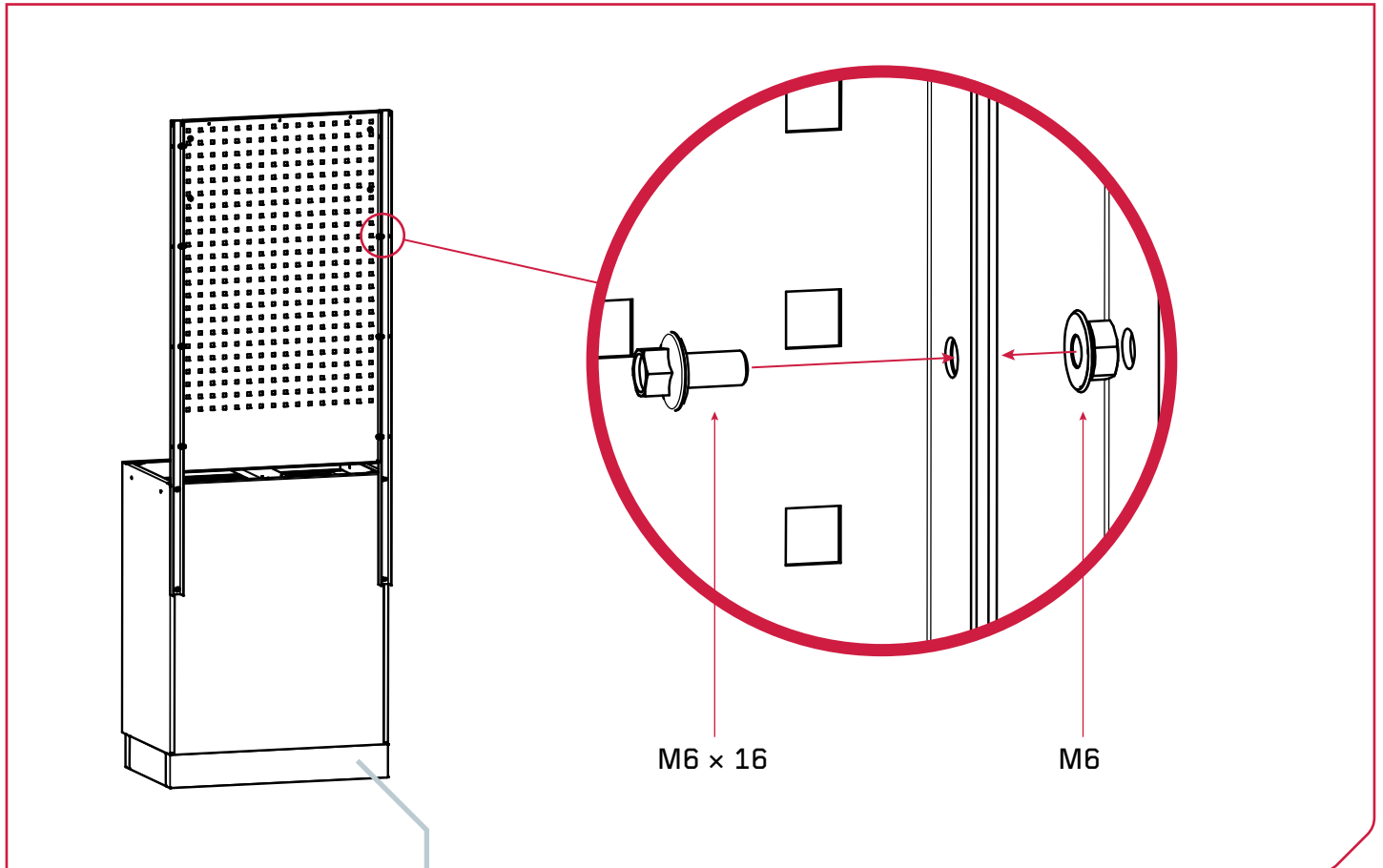

ZUTREFFENDE TEILE

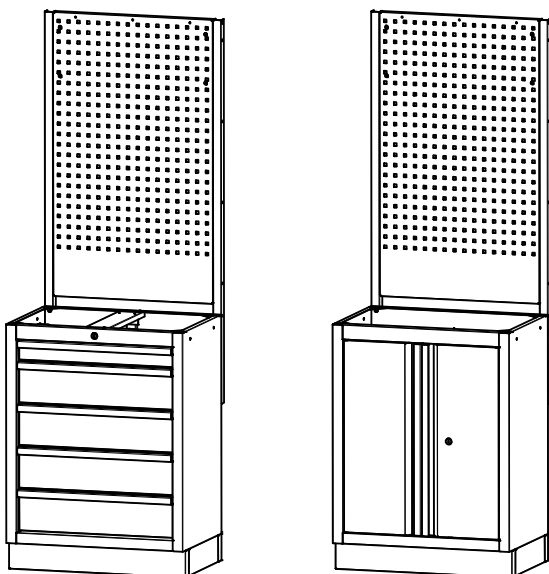

BENÖTIGTE SCHRAUBEN

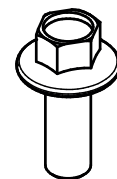

M6 x 16



M6

4. SCHRITT Container verbinden

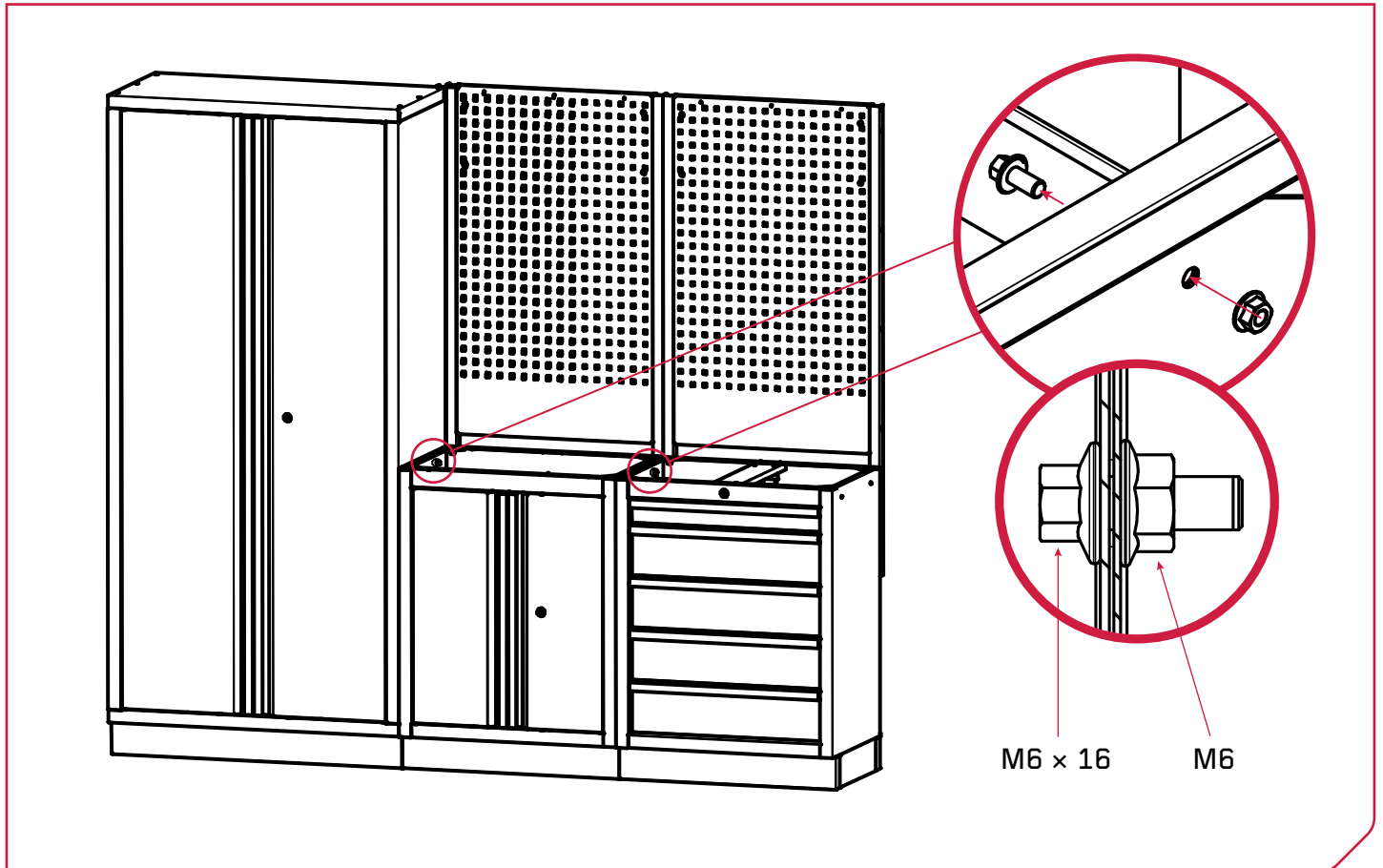

BENÖTIGTE SCHRAUBEN

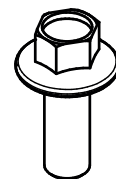

M6 x 16



M6

5. SCHRITT **Arbeitsplatte befestigen**

ZUNÄCHST SCHUBLADEN ENTFERNEN

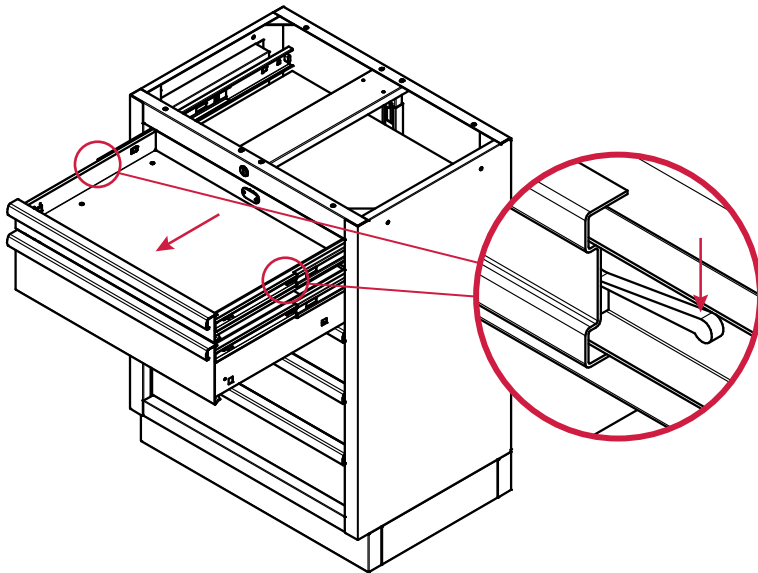

BENÖTIGTE SCHRAUBEN

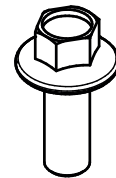

M6 x 16

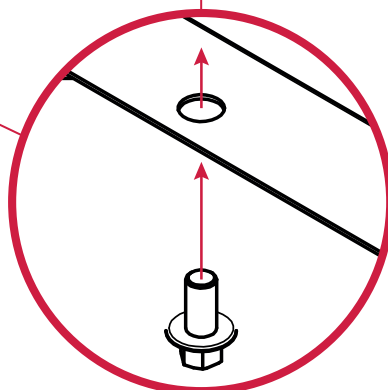
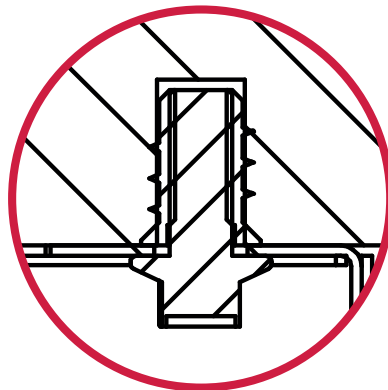
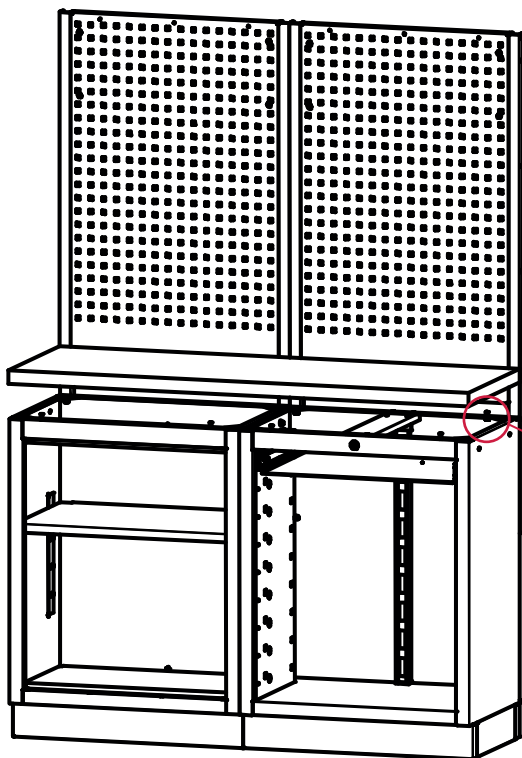

6. SCHRITT Rückwände verbinden

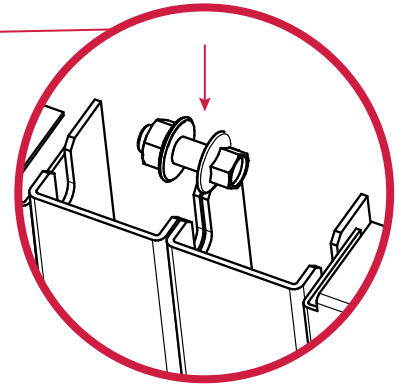
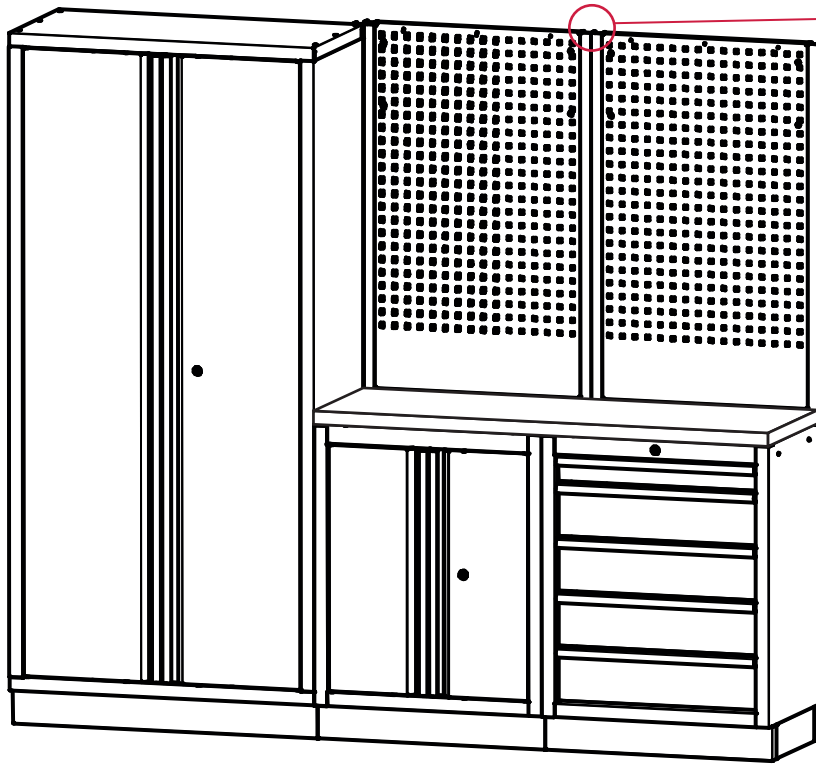

BENÖTIGTE SCHRAUBEN

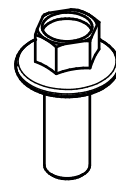

M6 x 16



M6

7. SCHRITT Hängeschränke

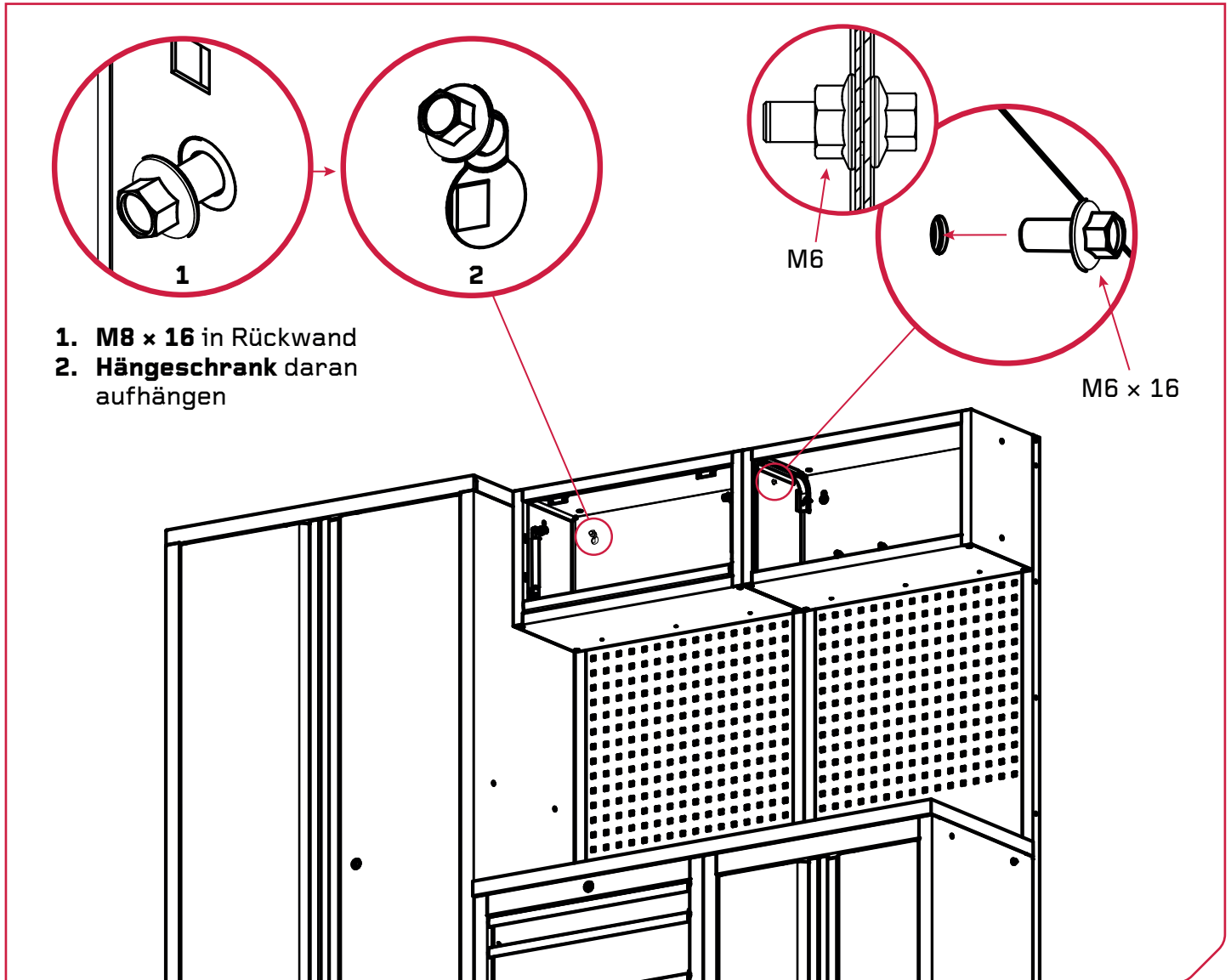

BENÖTIGTE SCHRAUBEN

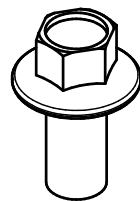

M8 x 16

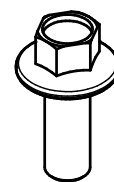

M6 x 16



M6

FEISTOS



MONTAGE- & BETRIEBSANLEITUNG

Doppeltür Schrank

Teil von Apollo 15 • FE991015

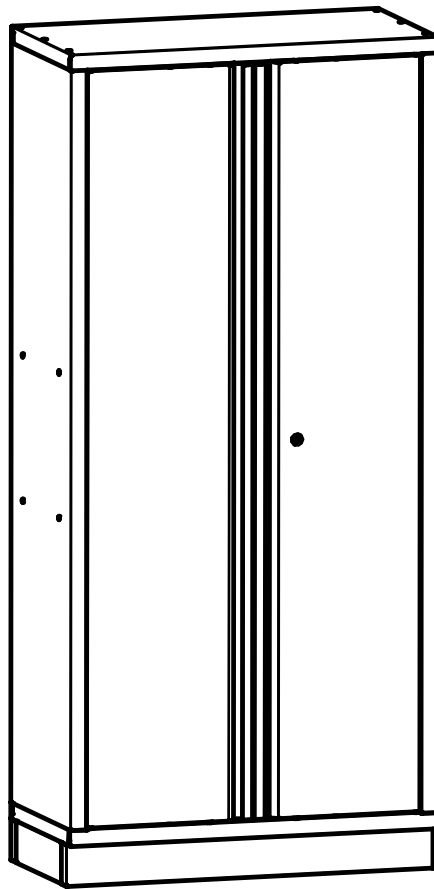

Warnung: Gefahr durch sehr hohes Gewicht!

Benutzen Sie zwei oder mehr Personen, um die Schränke und Spinde zu bewegen, zusammenzubauen oder zu installieren, um Rückenverletzungen zu vermeiden. Lassen Sie Kinder nicht unbeaufsichtigt in der Nähe von Schränken.



BEI FRAGEN, KONTAKTIEREN SIE UNSEREN KUNDENSERVICE:

50NRTH GmbH
Straßburgstraße 14-16
D-54516 Wittlich

service@50NRTH.com
+49 (0) 6571 95117-0

ANLEITUNG **DOPPELTÜR SCHRANK**

BENÖTIGTES WERKZEUG



Sechskant
Schraubenschlüssel
passend zu Schrauben
(siehe unten)

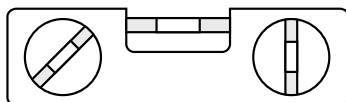

Wasserwaage



Akku-Schrauber
inkl. Bit-Satz
(siehe Schrauben (PH))

SCHRAUBEN

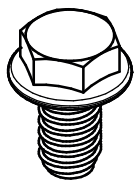

Sechskant-
Schraube
M6 x 12



Schrauben-
Mutter
M6

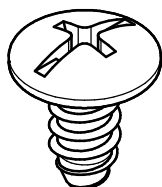

PH-Kreuz
Schraube
ST6 x 12

BAUTEILE BEZEICHNUNGEN

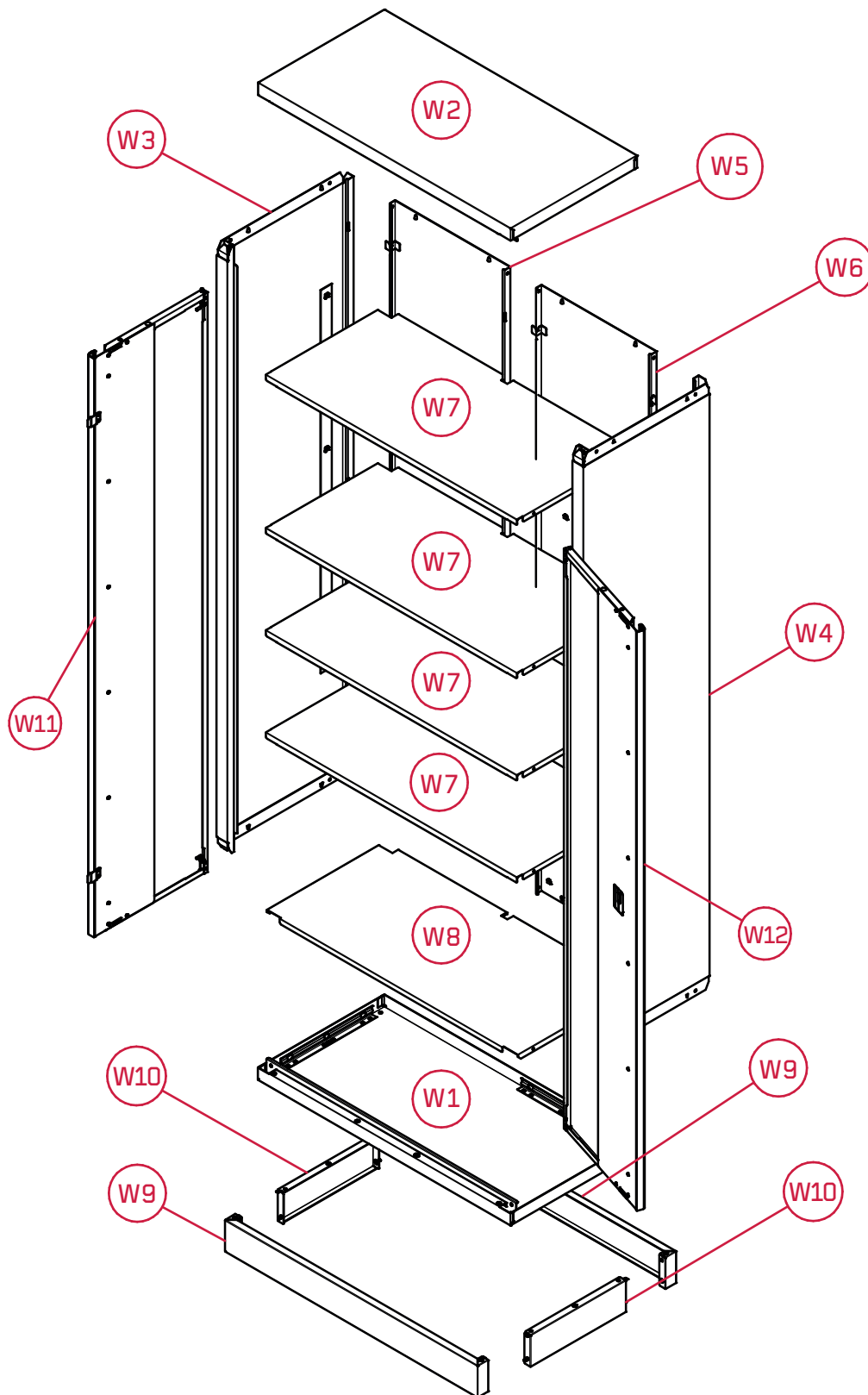

W1 × 1
W2 × 1
W3 × 1
W4 × 1
W5 × 1
W6 × 1
W7 × 4
W8 × 1
W9 × 2
W10 × 2
W11 × 1
W12 × 1

1. SCHRITT Fuß

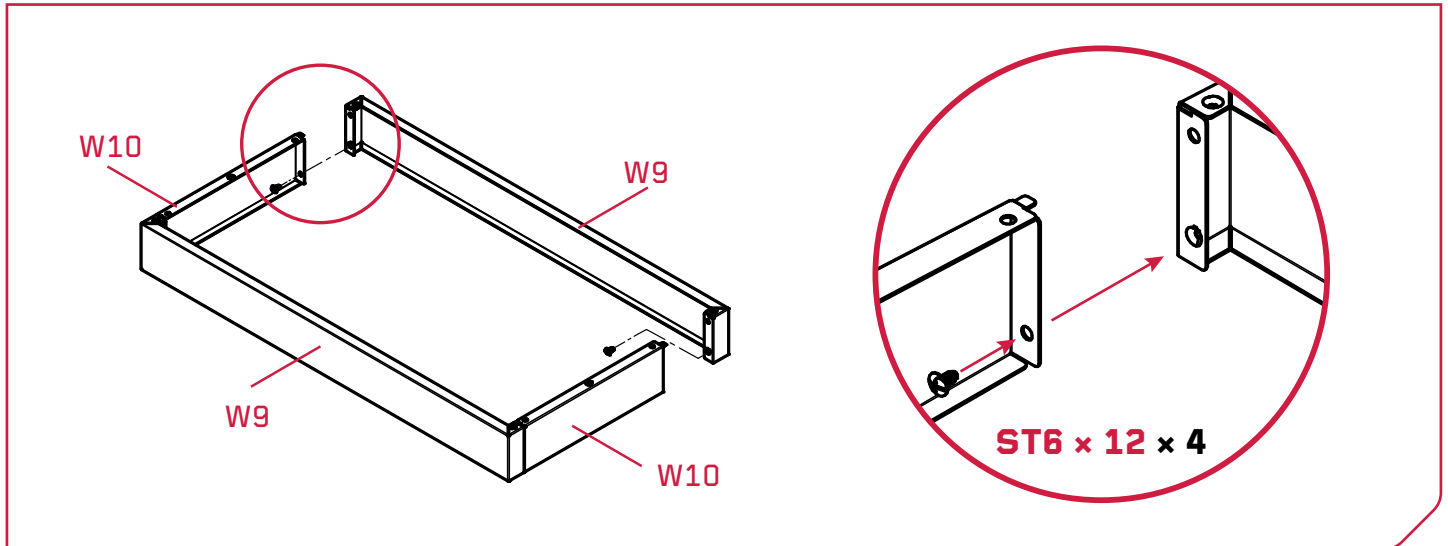

2. SCHRITT Boden und Fuß

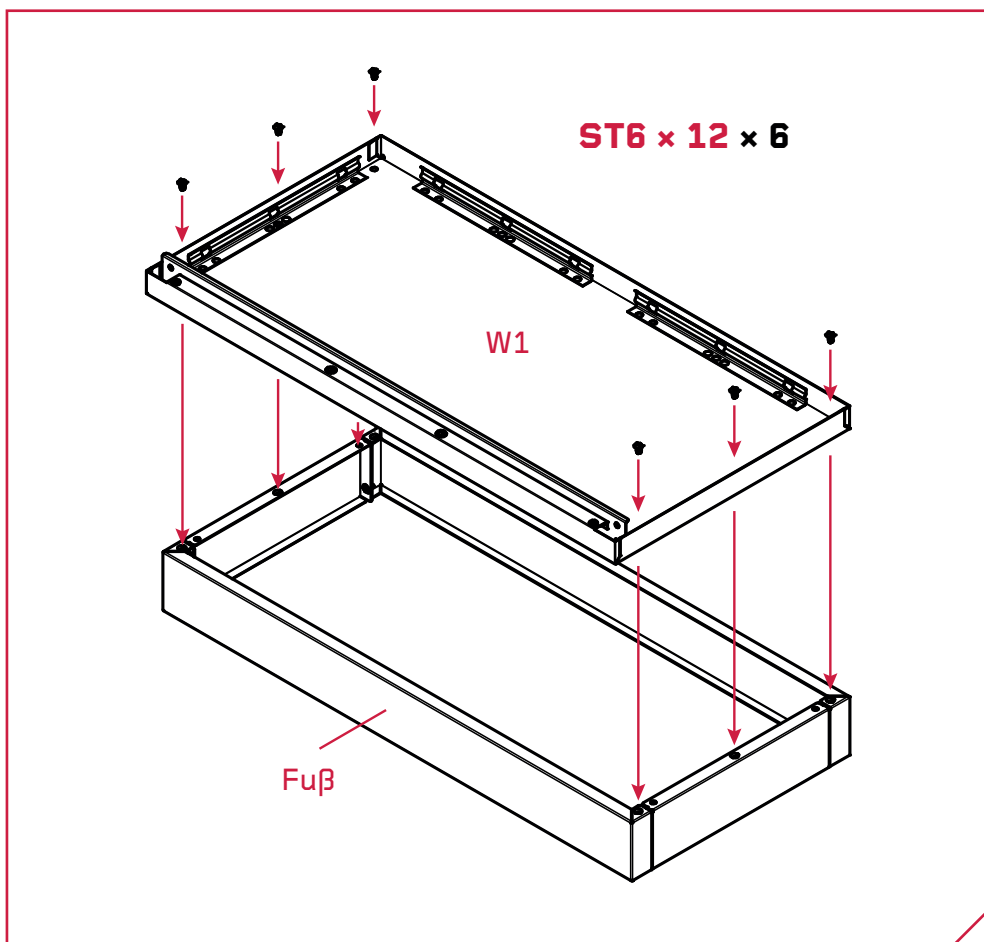

3. SCHRITT

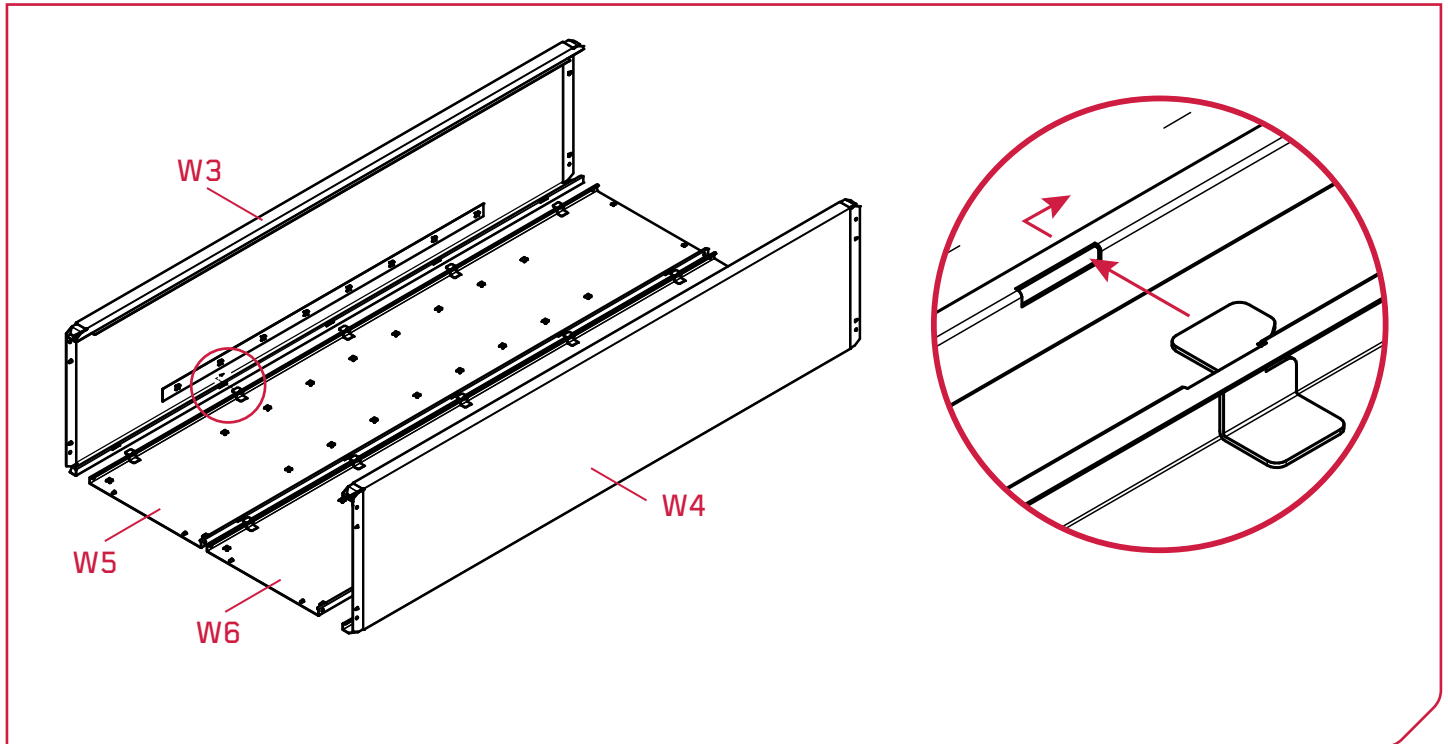

4. SCHRITT

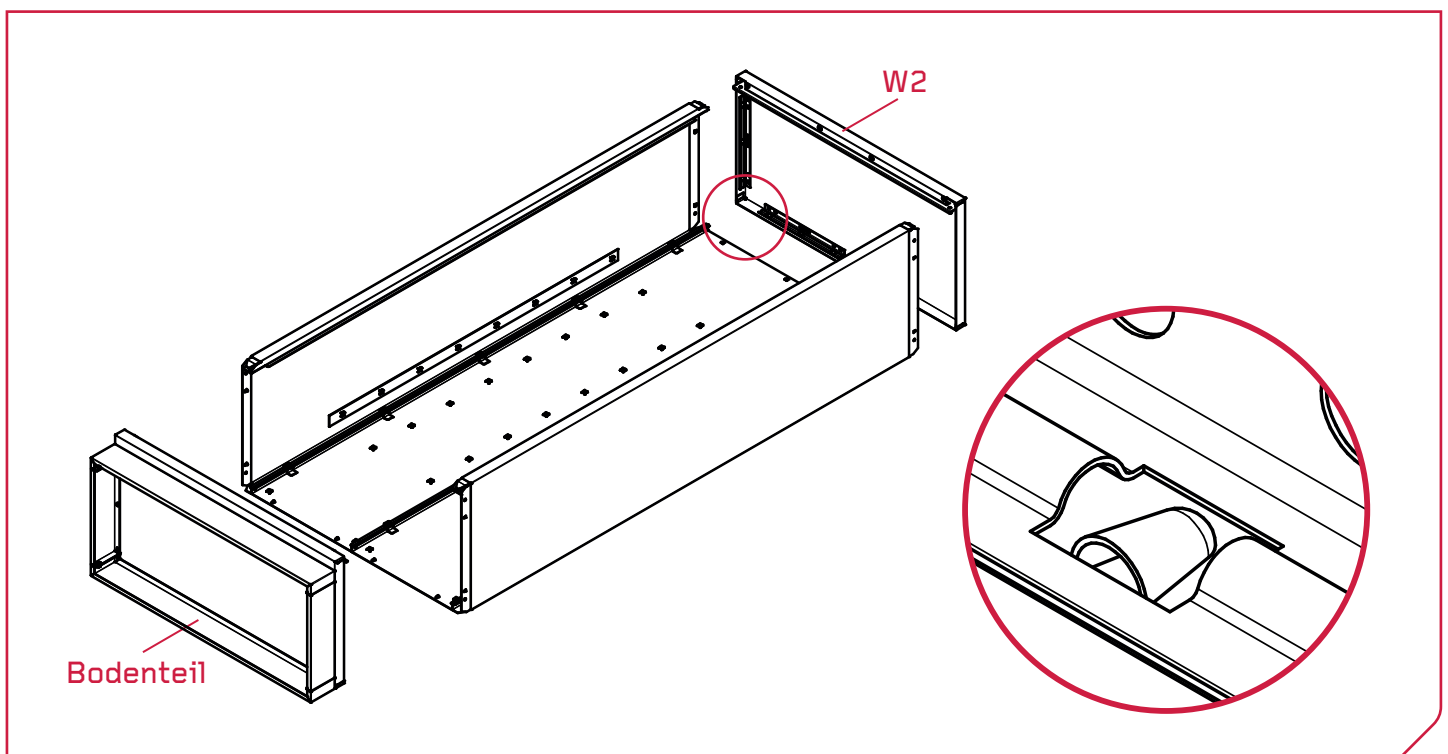

5. SCHRITT

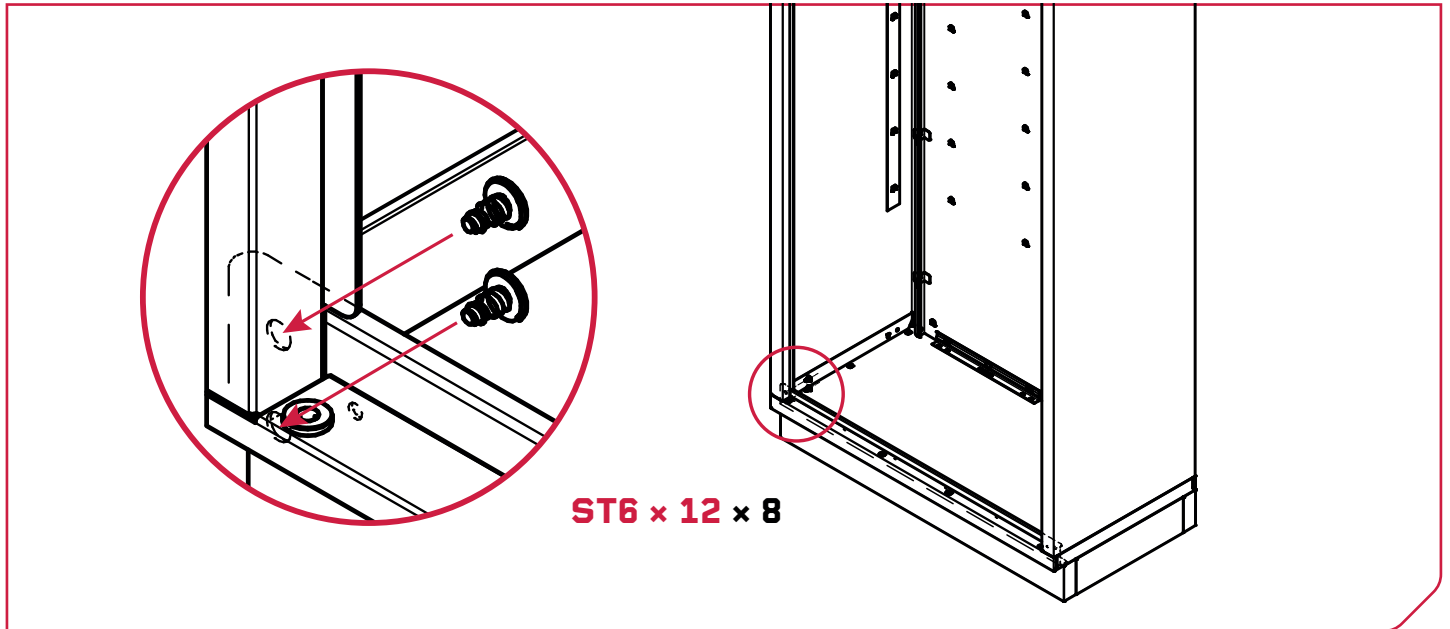

6. SCHRITT

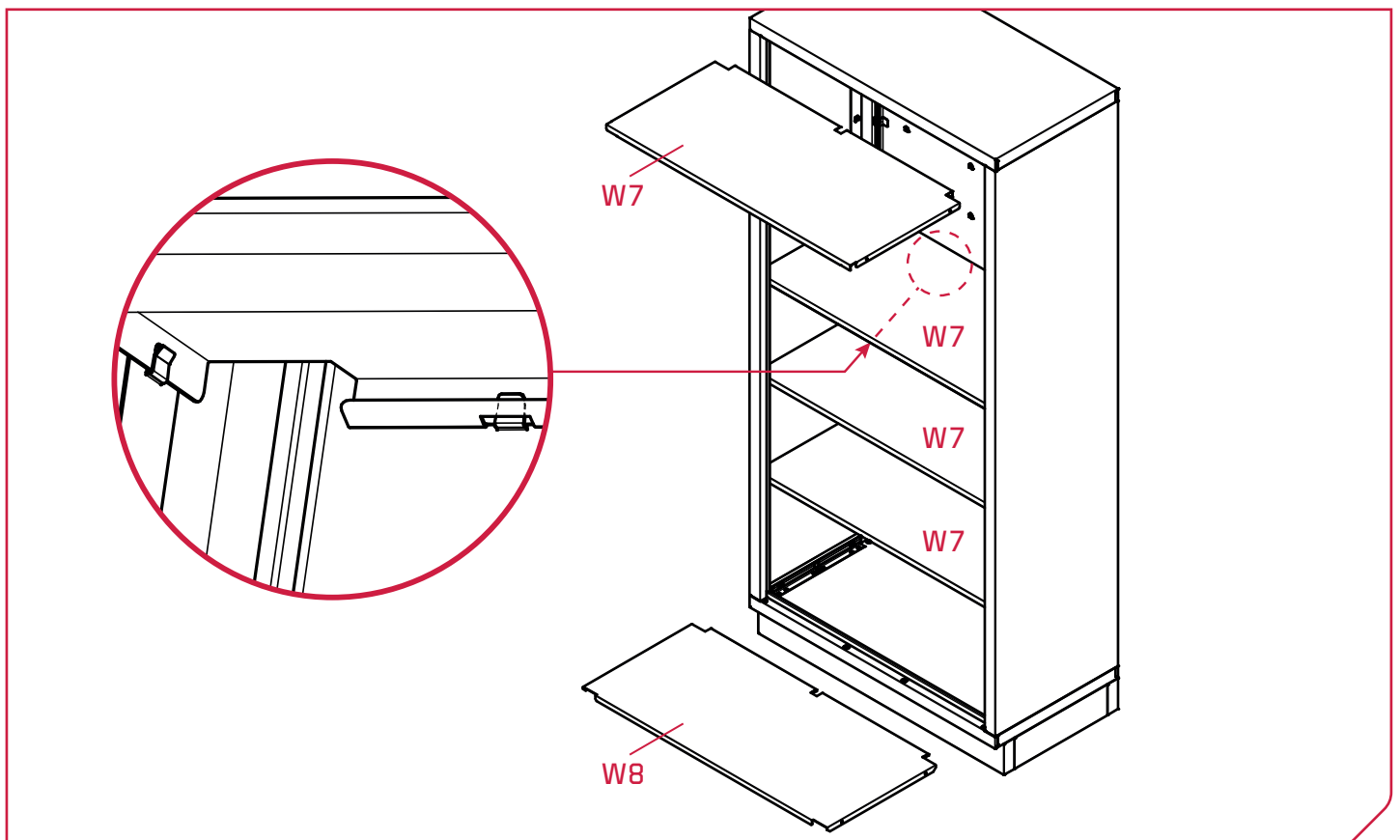

7. SCHRITT

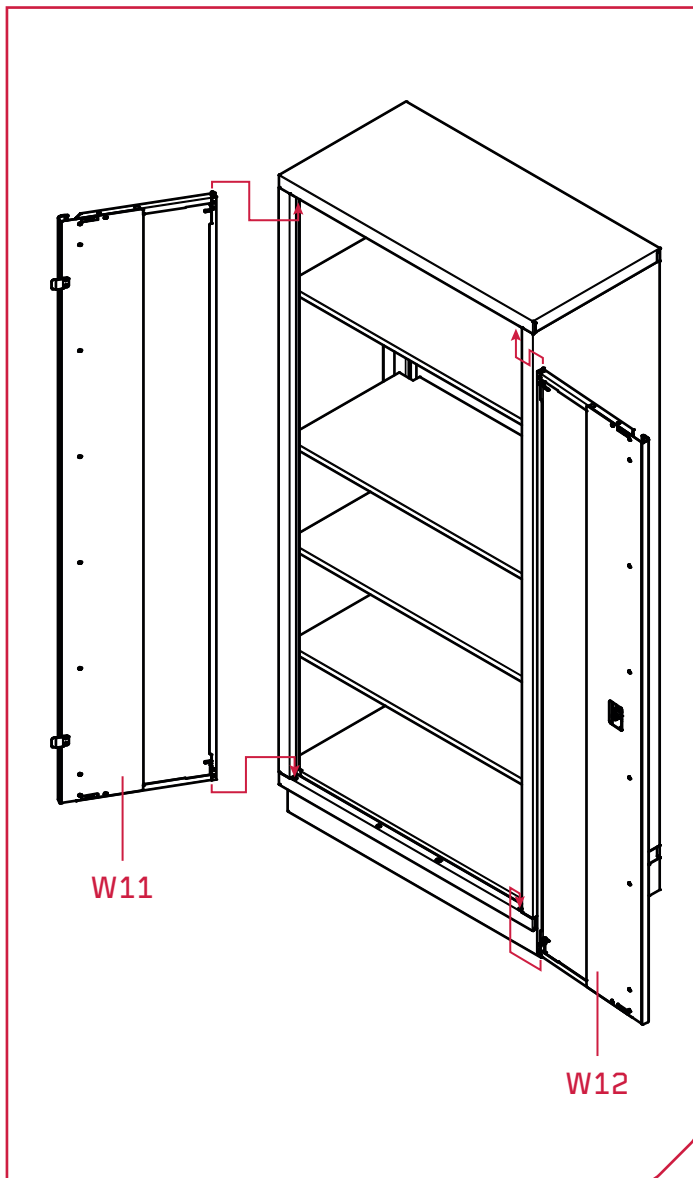

8. SCHRITT

